

Original instructions

Fan Coil Duct

Medium Static Pressure Fan Coil Unit

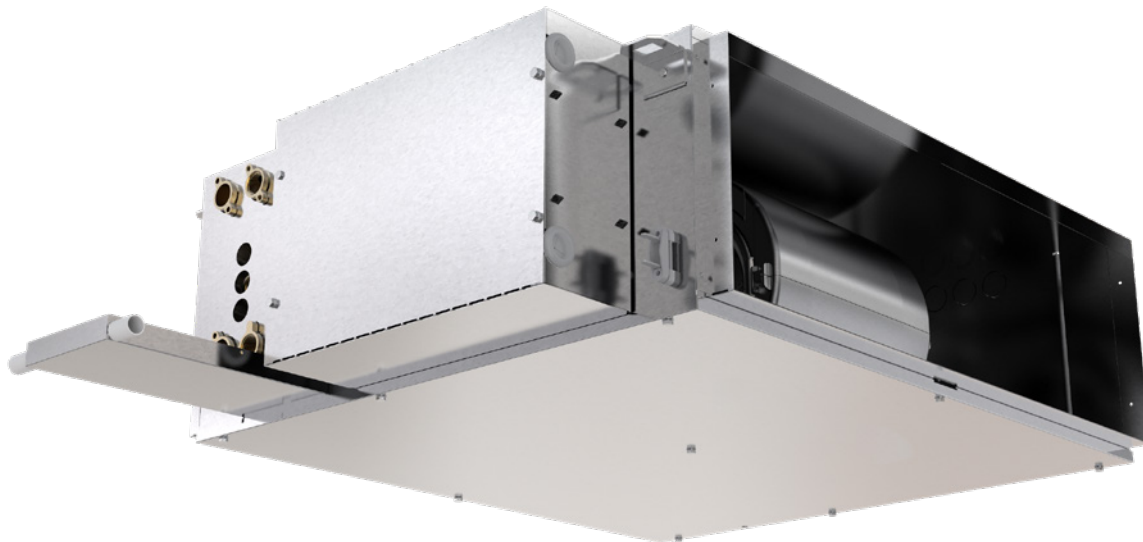

Model No. EC Fan Motor

Size	Hydraulic right - Electric left		Hydraulic right - Electric right	
	2 pipes	4 pipes	2 pipes	4 pipes
P-FD10	P-FD10AT-2EA	P-FD10AT-4EA	P-FD10AR-2EA	P-FD10AR-4EA
P-FD15	P-FD15AT-2EA	P-FD15AT-4EA	P-FD15AR-2EA	P-FD15AR-4EA
P-FD20	P-FD20AT-2EA	P-FD20AT-4EA	P-FD20AR-2EA	P-FD20AR-4EA
P-FD25	P-FD25AT-2EA	P-FD25AT-4EA	P-FD25AR-2EA	P-FD25AR-4EA
P-FD30	P-FD30AT-2EA	P-FD30AT-4EA	P-FD30AR-2EA	P-FD30AR-4EA
P-FD40	P-FD40AT-2EA	P-FD40AT-4EA	P-FD40AR-2EA	P-FD40AR-4EA

Size	Hydraulic left - Electric right		Hydraulic left - Electric left	
	2 pipes	4 pipes	2 pipes	4 pipes
P-FD10	P-FD10AQ-2EA	P-FD10AQ-4EA	P-FD10AS-2EA	P-FD10AS-4EA
P-FD15	P-FD15AQ-2EA	P-FD15AQ-4EA	P-FD15AS-2EA	P-FD15AS-4EA
P-FD20	P-FD20AQ-2EA	P-FD20AQ-4EA	P-FD20AS-2EA	P-FD20AS-4EA
P-FD25	P-FD25AQ-2EA	P-FD25AQ-4EA	P-FD25AS-2EA	P-FD25AS-4EA
P-FD30	P-FD30AQ-2EA	P-FD30AQ-4EA	P-FD30AS-2EA	P-FD30AS-4EA
P-FD40	P-FD40AQ-2EA	P-FD40AQ-4EA	P-FD40AS-2EA	P-FD40AS-4EA

Specifications

Presentation

The new ductable medium static pressure fan coil units **P-FD EC** have been designed to meet market needs for false-ceiling installations and for air distribution by ductwork.

This new range offers the following advantages:

- ✔ Range available **only with EC motor** for significant energy savings.
- ✔ Reduced overall dimensions with low height (223 mm) for easy concealed installation.
- ✔ In line or side air diffusion.
- ✔ Configuration flexibility thanks to a modular conception.

The range is composed of **6 models**: P-FD10, P-FD15, P-FD20, P-FD25, P-FD30 and P-FD40, to ensure air flows up to 1400 m³/h and 100 Pa available static pressure.

To cover all possible applications, they are available in the following systems:

- ✔ 2-pipe cooling or heating only
- ✔ 2-pipe reversible
- ✔ 2-pipe / 2-wire (electric heater)
- ✔ 2-pipe / 2-wire (electric heater) reversible
- ✔ 4-pipe

Aeraulic configurations

P-FD EC fan coil units are available in 3 configurations:

- ✔ With rectangular return and rectangular discharge duct connections.
- ✔ With rectangular return and circular discharge duct connections.
- ✔ With circular or oblong return and circular discharge duct connections.

And with **4 aeraulic arrangements** for air distribution according to the room configuration:

- ✔ I: In line return and discharge.
- ✔ U: Return and discharge at same side.
- ✔ J: In line return, side discharge.
- ✔ L: Side return and in line discharge.

The duct connections are provided with 1, 2 or 3 circular (Ø200 mm or Ø250 mm) connecting collars according to the unit sizes and configurations.

The discharge duct connection is insulated with 10 mm thick closed cell polyethylene foam having M1 fire classification.

Config.	Return	Discharge	10	15	20	25	30	40
I	Rectangular	Rectangular	✔	✔	✔	✔	✔	✔
	Rectangular	1x Ø200mm	✔	✔	-	-	-	-
	Rectangular	2x Ø200mm	-	✔	✔	✔	✔	-
	Rectangular	3x Ø200mm	-	-	-	-	-	✔
	1x Ø200mm	1x Ø200mm	✔	✔	✔	-	-	-
	2x Ø200mm	2x Ø200mm	-	✔	✔	✔	✔	-
J	3x Ø200mm	3x Ø200mm	-	-	-	-	-	✔
	1x Ø250mm	1x Ø250mm	-	-	AS*	AS*	AS*	-
	1x Ø200mm	1x Ø200mm	✔	✔	✔	✔	✔	-
	3x Ø200mm	1x Ø200mm	-	-	-	-	-	✔
L	1x Ø250mm	1x Ø250mm	-	-	AS*	AS*	AS*	-
	1x Ø200mm	1x Ø200mm	✔	✔	✔	✔	✔	-
	1x Ø200mm	3x Ø200mm	-	-	-	-	-	✔
U	1x Ø250mm	1x Ø250mm	-	-	AS*	AS*	AS*	-
	1x Ø200mm	1x Ø200mm	✔	✔	✔	✔	✔	✔

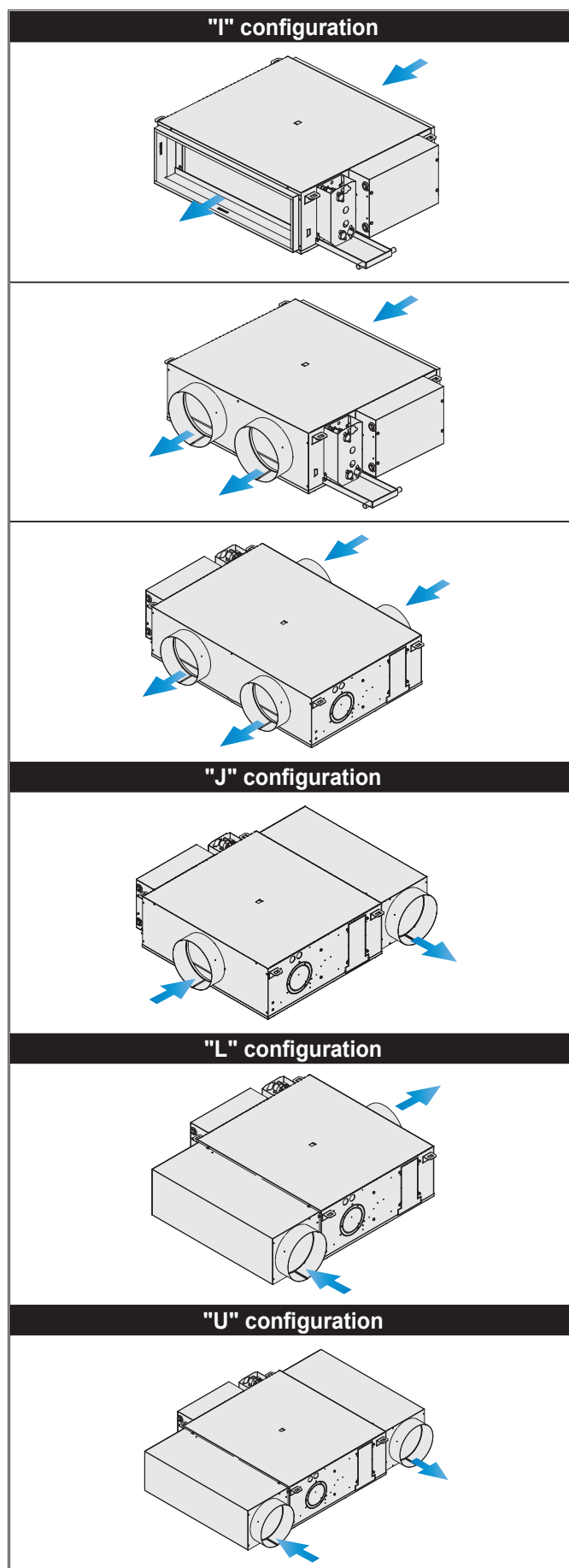

Specifications (continued)

Casing

Casing is fabricated from 0.8 mm thick galvanized steel sheet lined with closed cell polyethylene foam at discharge side.

The casing is fitted, as standard equipment, with pre-punched holes provided for fresh air intake.

The intake of fresh air can be assured by mounting collars of Ø100 or Ø125 mm (optional) on the pre-punched hole located at the opposite side of electrical box.

The condensate drain pan is made from 1.0 mm thick galvanized sheet steel, painted to provide corrosion protection, and is externally insulated by 4 mm thick closed cell polyethylene foam, having M1 fire classification.

The condensate drain pan is of monobloc type with an extension in order to collect condensates from water connections and valves.

The condensate drain pan has 2 connecting pipes of 5/8" diameter.

Access to internal components (fan-motor assembly and coils) for service and maintenance works is facilitated by dismantling the bottom panel of the fan coil unit, without removing the distribution ducts.

The hydraulic and electrical connections can be carried out at the same service side or at the opposite service side.

Fixation

Units fixation is done using 4 fixing brackets located at the upper side of the fan coil unit for a quick and easy installation and operation. Dismounting is facilitated with easy access to all components.

Coil compartment

Coil compartment is lined with 10 mm thick closed cell polyethylene foam insulation, having M1 fire classification.

Coils are made of copper tubes, mechanically expanded into hydrophilic aluminium fins, assuring optimum heat transfer between air and water.

Each **P-FD EC** fan coil unit is equipped with a 3-row cooling coil for 2-pipe or 2-pipe/2-wire system, plus 1-row heating coil for 4-pipe system.

The water connection of each header is 1/2" or 3/4" gas female threaded type according to the unit sizes and configurations.

Each circuit is fed through a header fitted with drain plug and air vent.

Coils are leak tested under water (21 bar) and are suitable for a maximum working pressure of 10 bar.

For 2-pipe / 2-wire system, electric heater consists of heating rod type resistance directly inserted in the coil or heating elements according to the unit sizes and configurations.

Fan compartment

The fan compartment is fitted with a fan-motor assembly of which the fan is composed of wheels with ABS plastic blades aero-dynamically profiled or of double inlet forward curved centrifugal type aluminium wheels. Scrolls are of ABS plastic type.

The fan-motor assembly is **exclusively of EC motor** type with high efficiency and low electrical consumption for a significant energy saving. The motor is suitable for 0-10V input, ensuring variable speed capability. It is fitted with Ecospeed 3 interface card (supplied as option) for a 3-speed optimized running.

The ductable fan coil units are of **A** or **B** energy class in cooling mode and of **A** energy class in heating mode according to Eurovent.

Electrical connections

Fan-motor assembly and valves motors are electrically wired terminating in a junction block protected by a cap.

Technical spaces allow easy installation of optional control systems supplied by the factory or others.

Nominal voltage: 230 V±10%/1 Ph/50-60 Hz

Options and accessories

➤ Air filter

Filter consists of cleanable synthetic media (sewn on wire frame), having G2 or G3 efficiency classification and M1 fire classification.

Filter is removable and is easily pulled out downward for cleaning or replacement, after removing the access metal plate.

➤ Electric heater for 2-pipe / 2-wire system

Electric heater consists of heating rod type resistances or heating elements according to the unit sizes and configurations equipped with a manual reset and an automatic reset high temperature cutout switches.

➤ Duct connections

Units can be equipped as standard with different duct connections at return and discharge side according to the model and aeraulic configuration (see table on page 1).

Other aeraulic configurations are available upon request.

➤ Regulation valves

On/Off (thermal type actuator), 2-way or 4-way type for 2-pipe or 4-pipe systems and are supplied mounted on the unit or loose.

Specifications (continued)

➤ Controls

P-FD EC fan coil units can be factory fitted with the following optional controls:

- ✔ Electronic communicating Plogic (zone controller) with group/ centralized control and Modbus connection

Plogic control



P-FD EC fan coil units can also be fitted, as accessory, with electromechanical or electronic control for wall mounting: TRM-FA, TControl EASY 3S, TControl POD glass, PAW-FC-RC1, PAW-FC-903EC, PAW-FC-907EC, PAW-FC-903AC, PAW-FC-907AC.

TRM-FA



TControl EASY 3S



TControl POD glass



PAW-FC-RC1



PAW-FC-903EC, PAW-FC-907EC, PAW-FC-903AC, PAW-FC-907AC



➤ Condensate pump

A condensate pump is supplied factory mounted to pump out condensates.

➤ Fuse holder

A fuse holder with fuse can be supplied as optional to protect the unit.

➤ Fresh air intake

The intake of fresh air can be assured by a pre-cut opening of Ø100 or Ø125 mm.

➤ Change-over mechanical sensor

A change-over mechanical sensor for TRM control can be supplied as optional.

Electrical Data

Electrical data (except for controller and Ecospeed 3 board)

Models	Absorbed power (W)					
	P-FD10	P-FD15	P-FD20	P-FD25	P-FD30	P-FD40
SLS	/	2	2	12	9	/
V1	8	8	18	26	9	10
V2	13	21	30	34	28	34
V3	24	30	47	41	65	65
V4	38	41	58	56	124	114
V5	49	60	72	69	163	205
Maximum	/	100	100	182	163	/

Values at 50 Pa static pressure available in V3 speed

Set-point voltage

Models	Voltage (V)					
	P-FD10	P-FD15	P-FD20	P-FD25	P-FD30	P-FD40
SLS	2.0	2.0	2.0	2.0	2.0	2.0
V1 - LS*	2.0	3.8	4.8	3.1	2.0	2.1
V2	3.8	5.2	6.1	3.5	4.0	3.9
V3 - MS	7.35	6.0	7.1	3.9	6.0	5.5
V4	8.2	6.9	7.6	4.4	8.0	7.1
V5 - HS	9.6	8.2	8.9	4.9	10.0	10.0
Maximum	10.0	10.0	10.0	10.0	10.0	10.0

(*) Minimum voltage, in case of use of electric heater (2-pipe/2-wire version).

Energy class



Energy class		P-FD10	P-FD15	P-FD20
2-pipe	FCEER	A	B	B
	FCCOP	A	A	A
4-pipe	FCEER	B	B	B
	FCCOP	A	A	A

Energy class		P-FD20	P-FD30	P-FD40
2-pipe	FCEER	B	B	A
	FCCOP	A	B	A
4-pipe	FCEER	B	B	A
	FCCOP	A	B	A

Electric heating data

Models	P-FD10	P-FD15	P-FD20	P-FD25	P-FD30	P-FD40
Capacity (W)	BE1 500	600	600	1000	1000	1250
	BE2 /	1000	1000	2000	2000	2500

Coil Water Volume

Models	Water volume (l)		
	2-pipe	4-pipe	
		Cooling	Heating
P-FD10	0.64	0.62	0.19
P-FD15	0.70	0.68	0.23
P-FD20	0.80	0.77	0.27
P-FD25	0.90	0.85	0.31
P-FD30	0.90	0.85	0.31
P-FD40	1.50	1.80	0.45

Acoustical Data

P-FD10

Speeds	Type	Acoustical power per octave band (dB(A))						Lw dB(A)	Lp global (1)dB(A)	NR (1)
		125 Hz	250 Hz	500 Hz	1 kHz	2 kHz	4 kHz			
V1 - LS	Return + Radiated	17.0	21.9	16.5	17.9	15.6	22.1	27.1	20	<15
	Discharge	10.9	19.7	18.0	15.8	19.1	23.3	27.0		
V3 - MS	Return + Radiated	36.3	42.8	41.9	36.4	31.1	29.1	46.5	36	23
	Discharge	32.5	36.7	38.6	40.7	40.2	21.1	45.6		
V5 - HS	Return + Radiated	41.1	48.6	47.5	45.5	41.9	32.8	52.9	41	30
	Discharge	37.3	42.7	43.0	48.1	47.3	36.9	52.2		

Speeds	Lw Return + Radiated dB(A)	Lw Discharge dB(A)	Lp global (1) dB(A)	NR (1)
V1	27	27	20	< 15
V2	36	36	27	17
V3	47	46	36	23
V4	49	48	38	25
V5	53	52	41	30

According to Eurovent 8/2, data given for a unit with:

- 30 Pa external static pressure at medium speed.
- Rectangular return and discharge.
- Standard filter.

(1) Informative data, considering an hypothetical sound attenuation of the room and installation of 21 dB.

P-FD15

Speeds	Type	Acoustical power per octave band (dB(A))						Lw dB(A)	Lp global (1)dB(A)	NR (1)
		125 Hz	250 Hz	500 Hz	1 kHz	2 kHz	4 kHz			
V1 - LS	Return + Radiated	28.6	37.2	38.4	40.3	35.4	28.6	44.4	26	21
	Discharge	25.9	32.1	36.6	42.7	38.6	27.9	45.2		
V3 - MS	Return + Radiated	32.3	42.3	42.8	48.8	47.5	40.9	52.6	35	30
	Discharge	34.3	41.7	45.8	51.3	52.6	42.6	55.9		
V5 - HS	Return + Radiated	40.1	50.8	49.8	55.8	54.1	48.1	59.7	42	37
	Discharge	38.4	47.2	50.3	56.5	59	50.2	61.8		

Speeds	Lw Return + Radiated dB(A)	Lw Discharge dB(A)	Lp global (1) dB(A)	NR (1)
SPV	37.8	38.9	20	< 18
V1	44.4	45.2	26	21
V2	50	52.5	32	27
V3	52.6	55.9	35	30
V4	55	58.5	38	33
V5	59.7	61.8	42	37
Maximum	62	64	44	39

According to Eurovent 8/2, data given for a unit with:

- 50 Pa external static pressure at medium speed.
- Rectangular return and discharge.
- Standard filter.

(1) Informative data, considering an hypothetical sound attenuation of the room and installation of 21 dB.

Acoustical Data (continued)

P-FD20

Speeds	Type	Acoustical power per octave band (dB(A))						Lw dB(A)	Lp global (1)dB(A)	NR (1)
		125 Hz	250 Hz	500 Hz	1 kHz	2 kHz	4 kHz			
V1 - LS	Return + Radiated	32.1	39.5	39.3	41.4	37.3	31.2	46	28	23
	Discharge	29.1	35.3	40	46	41.8	31.2	48.5		
V3 - MS	Return + Radiated	39.4	47	46.2	50.2	46.9	40.9	54.2	36	31
	Discharge	35	42.6	46.5	52.1	53.4	43.4	56.7		
V5 - HS	Return + Radiated	42.6	51	49.1	54.6	51.5	45.9	58.4	40	35
	Discharge	37.3	46.3	49.4	55.5	58.1	49.1	60.9		

Speeds	Lw Return + Radiated dB(A)	Lw Discharge dB(A)	Lp global (1) dB(A)	NR (1)
SPV	38.5	39.4	21	< 18
V1	46	48.5	28	23
V2	51	53.5	33	28
V3	54.2	56.7	36	31
V4	55.3	57.8	37	32
V5	58.4	60.9	40	35
Maximum	62.2	64.3	44	39

According to Eurovent 8/2, data given for a unit with:

- 50 Pa external static pressure at medium speed.
- Rectangular return and discharge.
- Standard filter.

(1) Informative data, considering an hypothetical sound attenuation of the room and installation of 21 dB.

P-FD25

Speeds	Type	Acoustical power per octave band (dB(A))						Lw dB(A)	Lp global (1)dB(A)	NR (1)
		125 Hz	250 Hz	500 Hz	1 kHz	2 kHz	4 kHz			
V1 - LS	Return + Radiated	36.7	43.3	40.6	46.1	42	35.5	49.9	32	27
	Discharge	33.1	38	42.4	46.6	44.3	30.2	50		
V3 - MS	Return + Radiated	41.2	48.2	44.9	50.8	47.8	42.1	54.9	36	31
	Discharge	37.4	42.9	46.6	52.5	52.4	41	56.4		
V5 - HS	Return + Radiated	48.2	55.4	51.4	55.7	52.4	54.3	61.4	43	38
	Discharge	41.6	47.5	50.5	56.4	56.9	47.1	60.7		

Speeds	Lw Return + Radiated dB(A)	Lw Discharge dB(A)	Lp global (1) dB(A)	NR (1)
SPV	42.2	42.8	26	21
V1	49.9	50	32	27
V2	51.5	52.1	34	29
V3	54.9	56.4	36	31
V4	59.5	59	41	36
V5	61.4	60.7	43	38
Maximum	65.9	65.1	48	43

According to Eurovent 8/2, data given for a unit with:

- 50 Pa external static pressure at medium speed.
- Rectangular return and discharge.
- Standard filter.

(1) Informative data, considering an hypothetical sound attenuation of the room and installation of 21 dB.

Acoustical Data (continued)

P-FD30

Speeds	Type	Acoustical power per octave band (dB(A))						Lw dB(A)	Lp global (1)dB(A)	NR (1)
		125 Hz	250 Hz	500 Hz	1 kHz	2 kHz	4 kHz			
V1 - LS	Return + Radiated	42.2	35.2	31.0	25.8	23.1	20.1	43.4	25.9	23.0
	Discharge	43.4	35.1	29.8	28.0	21.5	10.3	44.3		
V3 - MS	Return + Radiated	42.5	49.7	52.2	49.5	45.1	37.5	56.1	40.2	55.0
	Discharge	43.0	50.4	53.6	55.1	53.4	40.3	59.6		
V5 - HS	Return + Radiated	52.1	59.5	61.6	59.5	56.3	51.3	66.0	50.3	66.0
	Discharge	52.7	60.5	63.1	65.2	64.1	55.2	69.8		

Speeds	Lw Return + Radiated dB(A)	Lw Discharge dB(A)	Lp global (1) dB(A)	NR (1)
V1	43.4	44.3	25.9	23
V2	48.8	48.0	31.4	26
V3	56.1	59.6	40.2	55
V4	61.5	61.4	43.4	38
V5	66.0	69.8	50.3	66

According to Eurovent 8/2, data given for a unit with:

- 50 Pa external static pressure at medium speed.
- Rectangular return and discharge.
- Standard filter.

(1) Informative data, considering an hypothetical sound attenuation of the room and installation of 21 dB.

P-FD40

Speeds	Type	Acoustical power per octave band (dB(A))						Lw dB(A)	Lp global (1)dB(A)	NR (1)
		125 Hz	250 Hz	500 Hz	1 kHz	2 kHz	4 kHz			
V1 - LS	Return + Radiated	36.2	44.2	35.2	29.0	26.2	29.9	45.5	34.4	21
	Discharge	30.7	32.7	33.4	31.8	23.9	20.1	38.5		
V3 - MS	Return + Radiated	41.8	48.1	46.2	44.2	32.6	30.6	51.8	44.1	35
	Discharge	41.6	47.8	53.9	54.8	53.6	42.7	59.4		
V5 - HS	Return + Radiated	54.4	63.4	62.5	62.2	58.5	52.6	68.3	56.5	46
	Discharge	51.6	58.4	64.1	65.2	64.3	57.3	70.0		

Speeds	Lw Return + Radiated dB(A)	Lw Discharge dB(A)	Lp global (1) dB(A)	NR (1)
V1	45	38	34	21
V2	48	52	40	30
V3	52	59	44	35
V4	57	64	50	40
V5	68	70	56	46

According to Eurovent 8/2, data given for a unit with:

- 50 Pa external static pressure at medium speed.
- Rectangular return and discharge.
- Standard filter.

(1) Informative data, considering an hypothetical sound attenuation of the room and installation of 21 dB.

Air Flow Data - P-FD10

In line I configuration - Rectangular return / Rectangular discharge - Air flow (m³/h)

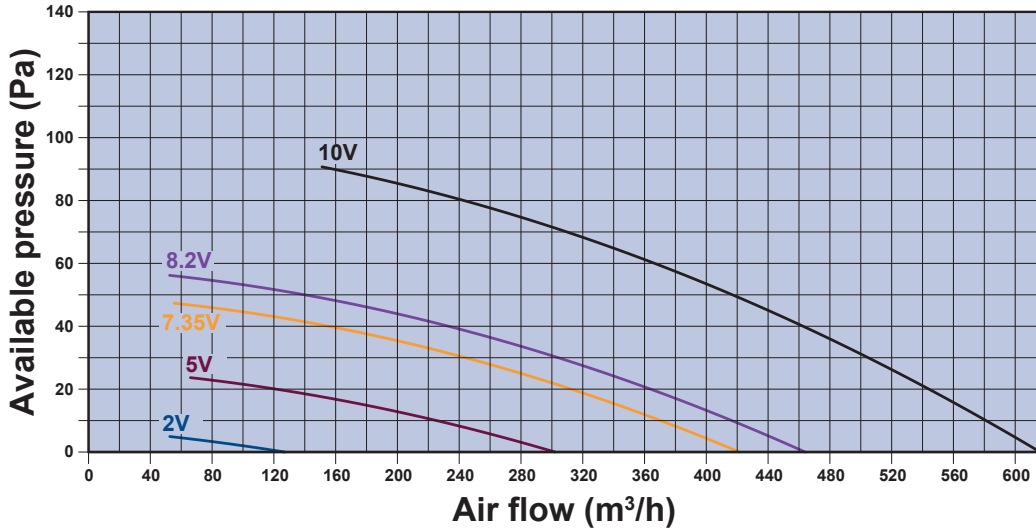

In line I configuration - Circular return / Circular discharge - 1x200 mm - Air flow (m³/h)

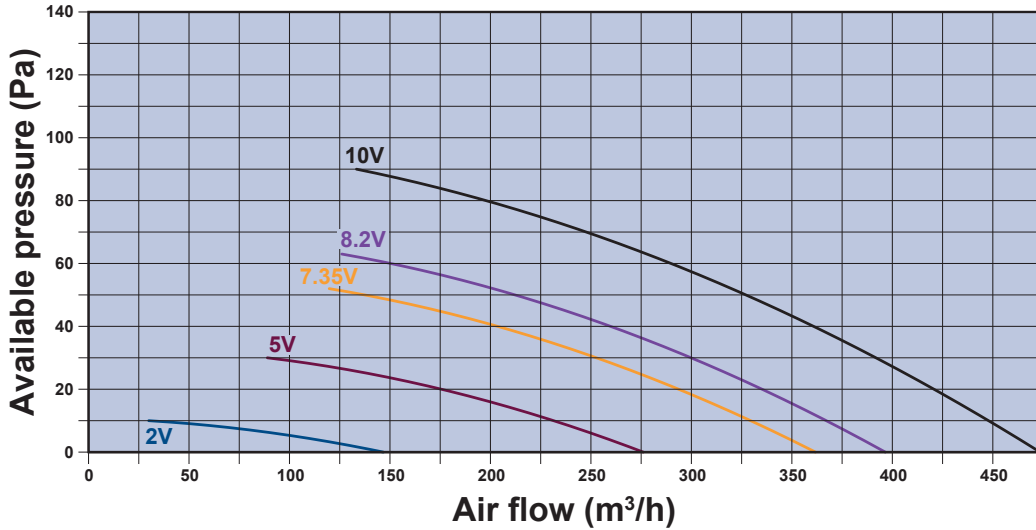

U configuration - Circular return / Circular discharge - 1x200 mm - Air flow (m³/h)

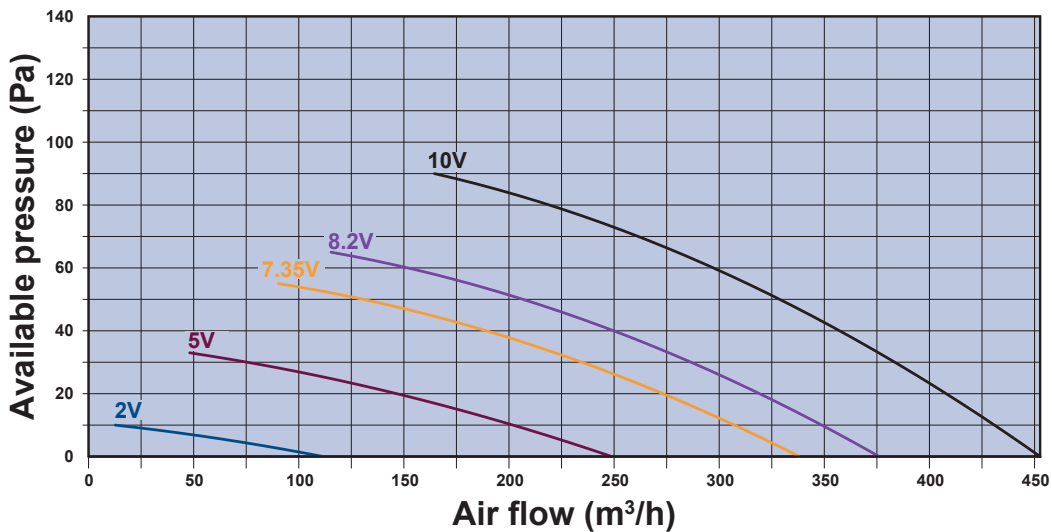

Air Flow Data - P-FD15

In line I configuration - Rectangular return / Rectangular discharge - Air flow (m³/h)

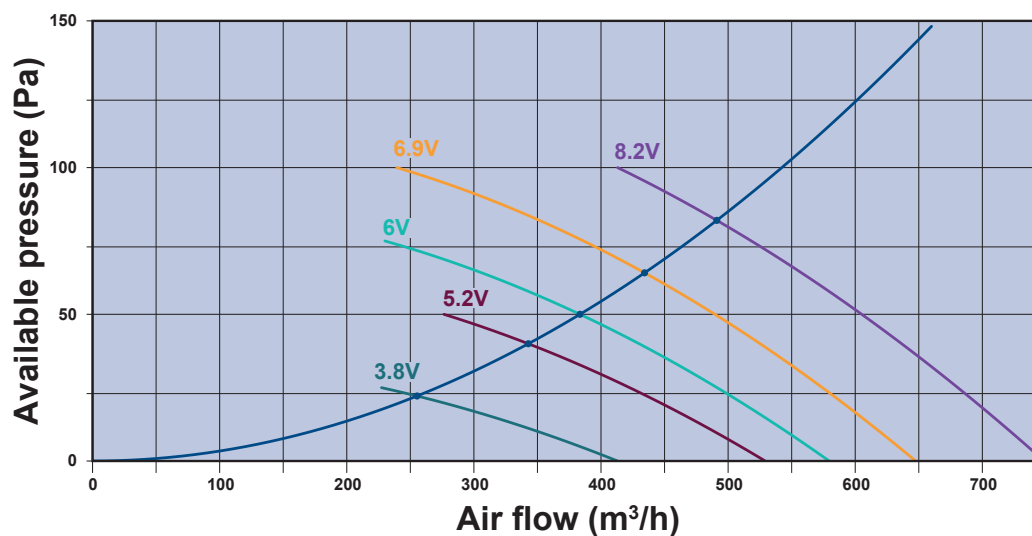

In line I configuration - Circular return / Circular discharge - 1x200 mm - Air flow (m³/h)

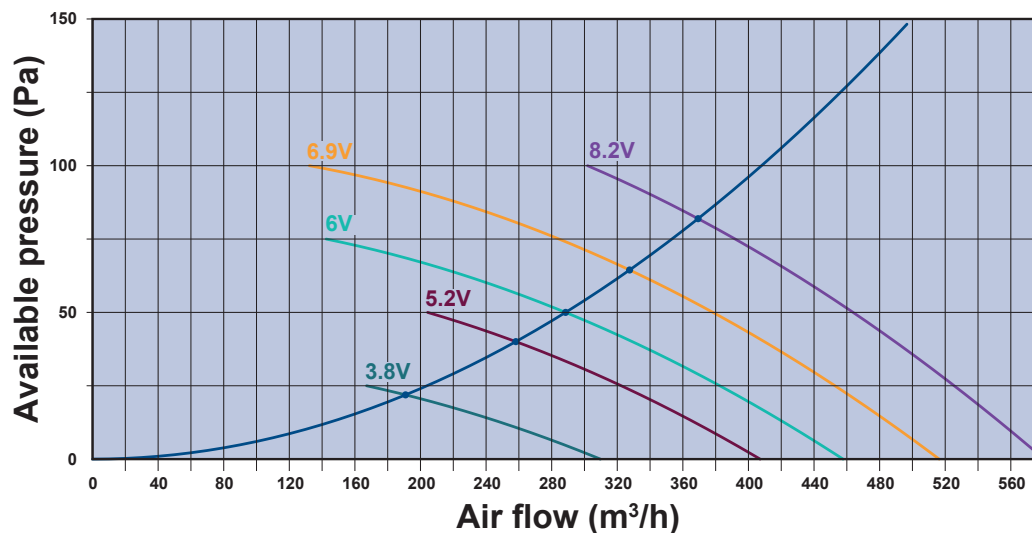

U configuration - Circular return / Circular discharge - 1x200 mm - Air flow (m³/h)

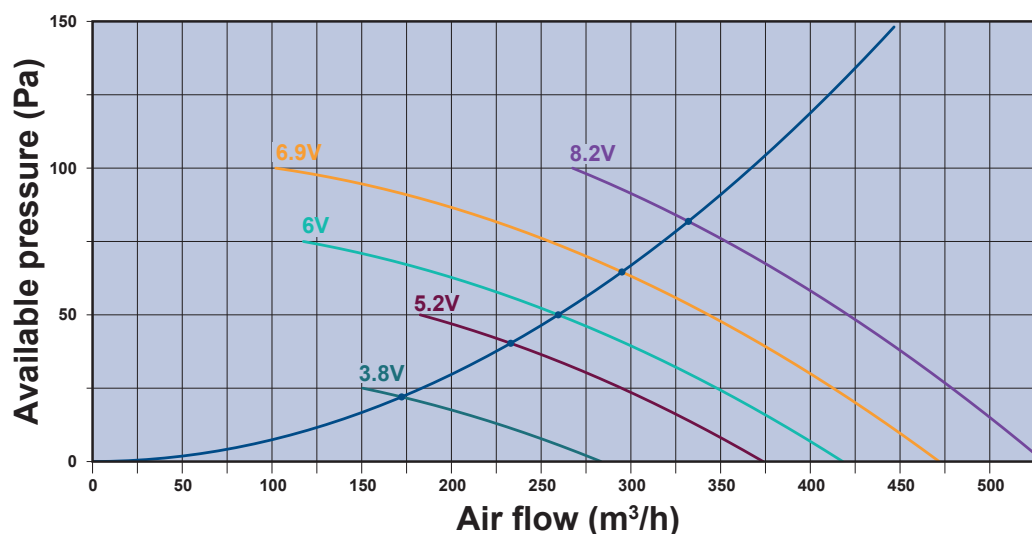

Air Flow Data - P-FD20

In line I configuration - Rectangular return / Rectangular discharge - Air flow (m³/h)

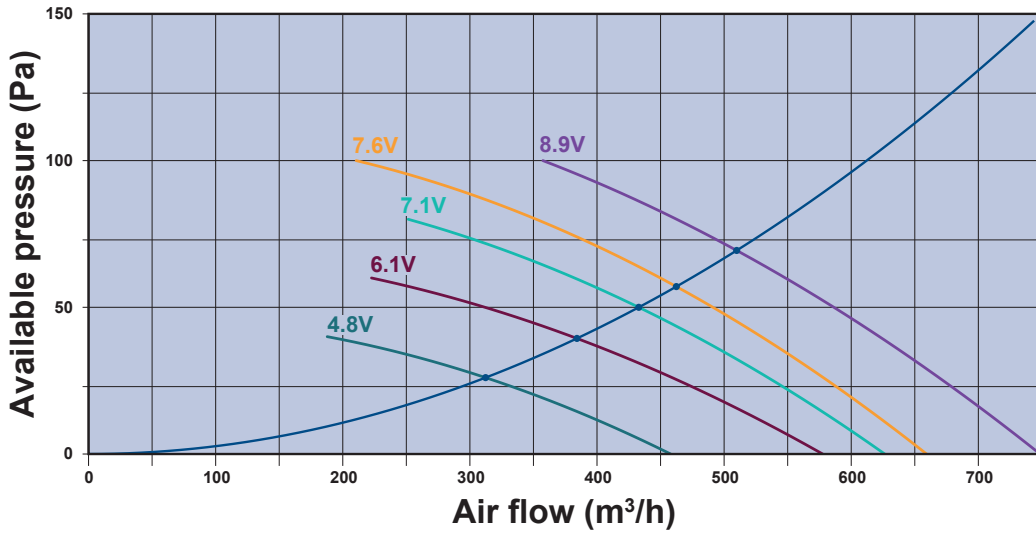

In line I configuration - Circular return / Circular discharge - 1x200 mm - Air flow (m³/h)

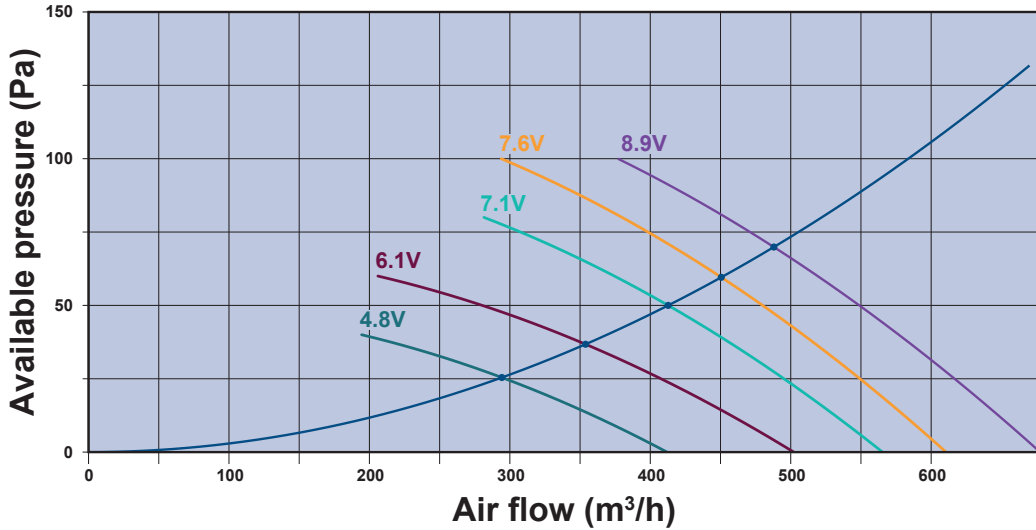

U configuration - Circular return / Circular discharge - 1x200 mm - Air flow (m³/h)

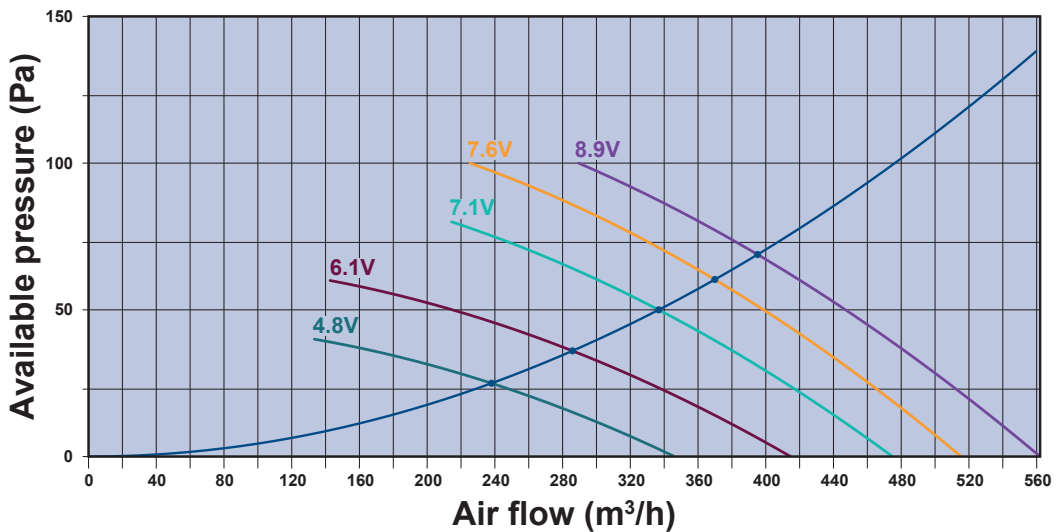

Air Flow Data - P-FD25

In line I configuration - Rectangular return / Rectangular discharge - Air flow (m³/h)

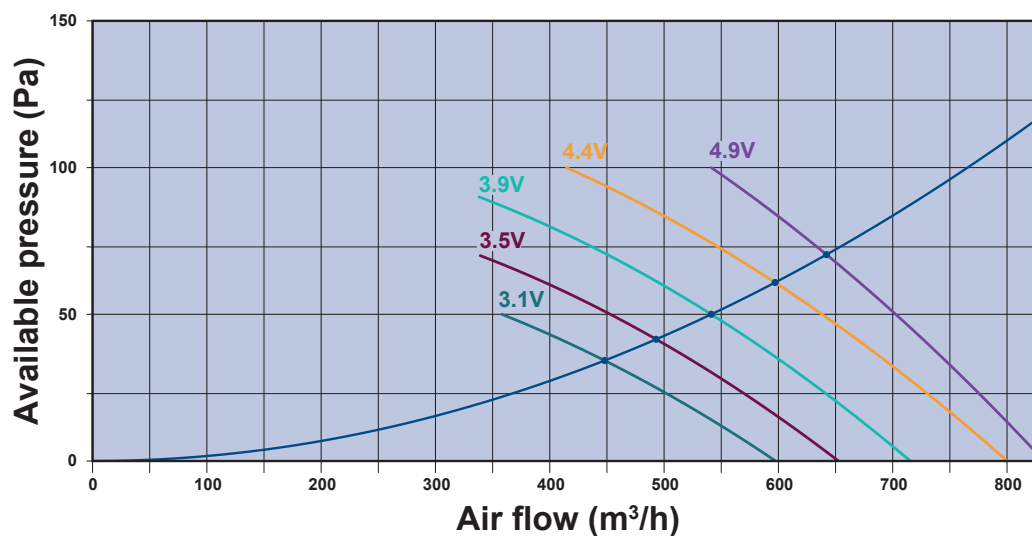

In line I configuration - Circular return / Circular discharge - 2x200 mm - Air flow (m³/h)

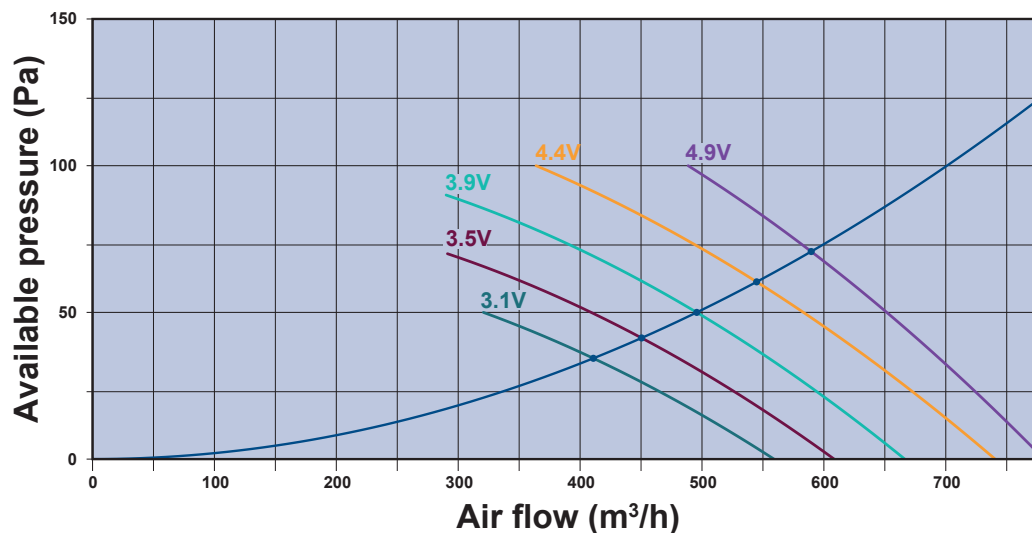

U configuration - Circular return / Circular discharge - 1x200 mm - Air flow (m³/h)

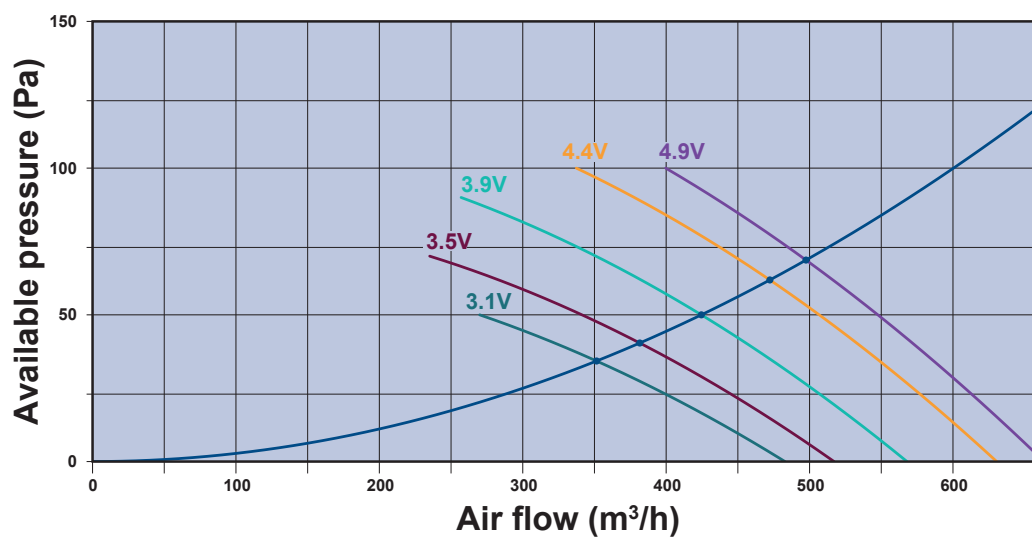

Air Flow Data - P-FD30

In line I configuration - Rectangular return / Rectangular discharge - Air flow (m³/h)

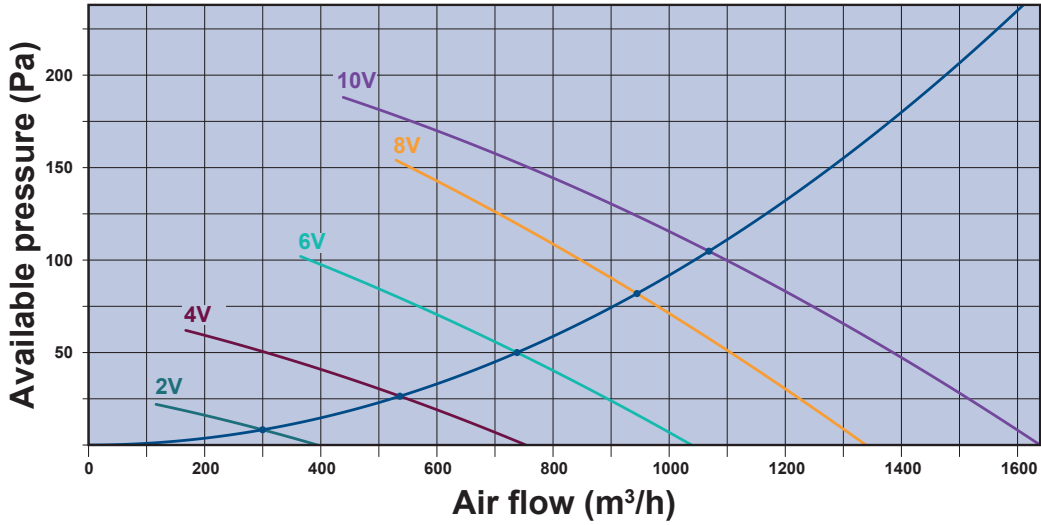

In line I configuration - Circular return / Circular discharge - 2x200 mm - Air flow (m³/h)

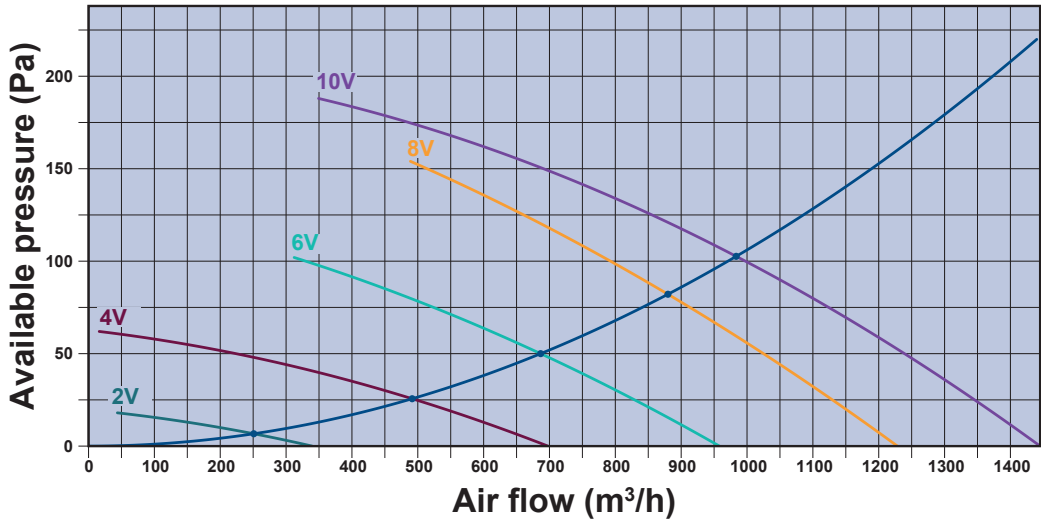

U configuration - Circular return / Circular discharge - 1x200 mm - Air flow (m³/h)

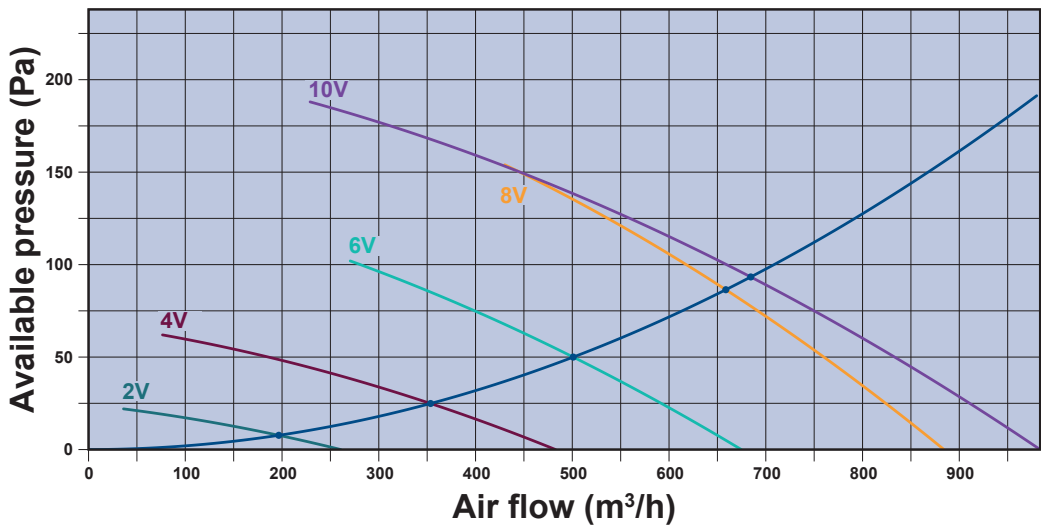

Air Flow Data - P-FD40

In line I configuration - Rectangular return / Rectangular discharge - Air flow (m³/h)

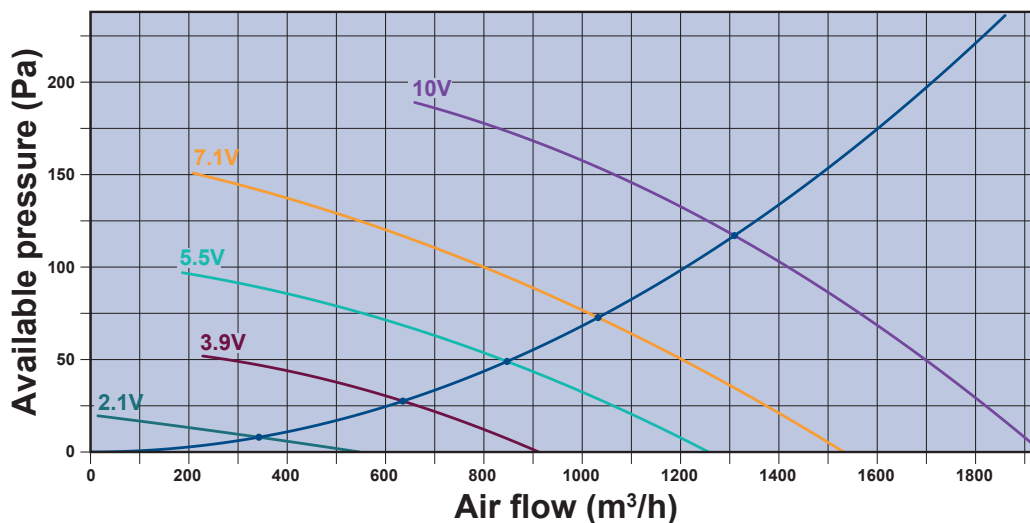

In line I configuration - Circular return / Circular discharge - 3x200 mm - Air flow (m³/h)

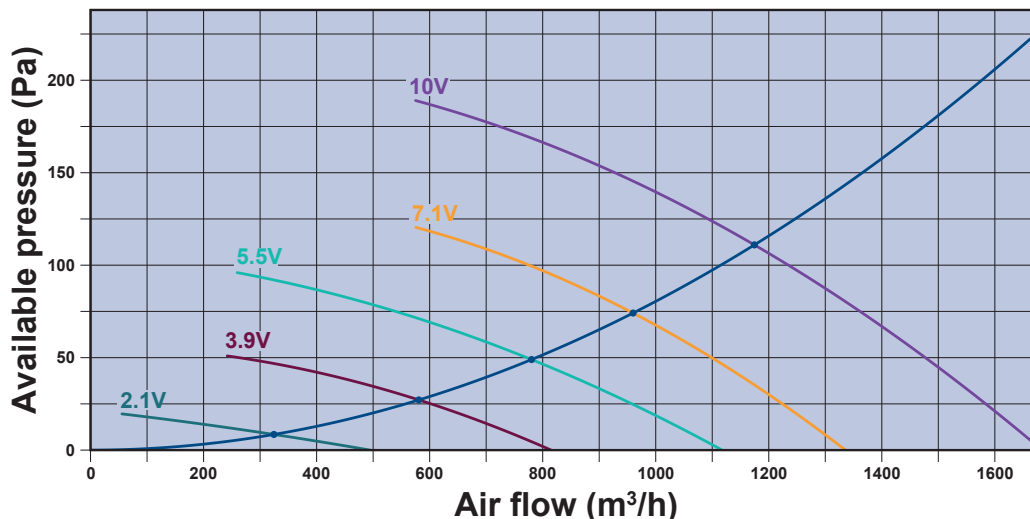

U configuration - Circular return / Circular discharge - 1x200 mm - Air flow (m³/h)

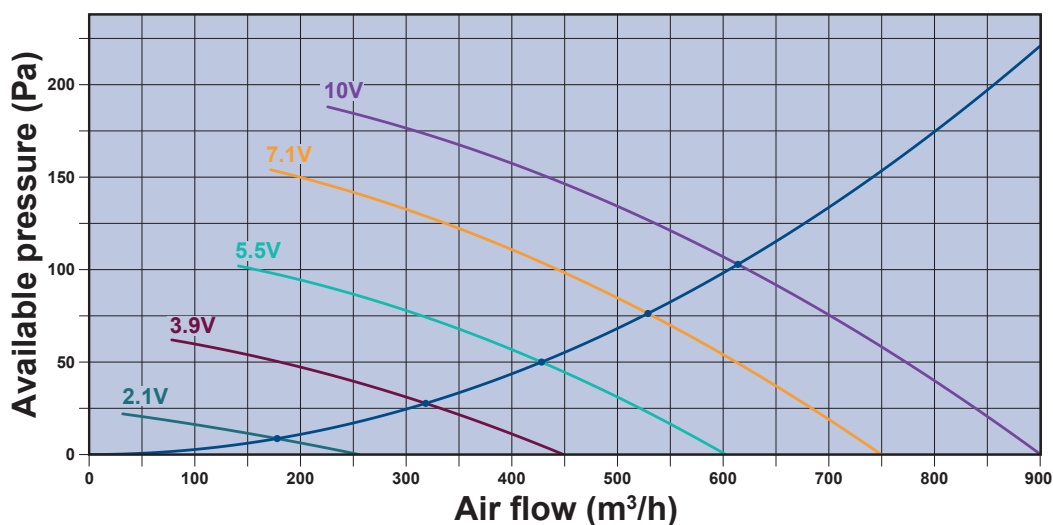

Performance Data - P-FD10

2-pipe - In line I configuration - Rectangular return / discharge - filter G3

Speeds	Air flow (m³/h)	Water flow (l/h)	Cooling mode (1)		Heating mode (2)
			Total capacity (W)	Sensible capacity (W)	Heating capacity (W)
V1 - LS	90	103	597	497	672
V2	150	163	946	791	1085
V3 - MS	270	263	1526	1287	1827
V4	300	274	1646	1392	1995
V5 - HS	350	314	1826	1551	2259

4-pipe - In line I configuration - Rectangular return / discharge - filter G3

Speeds	Air flow (m³/h)	Cooling mode (1)			Heating mode (3)	
		Water flow (l/h)	Total capacity (W)	Sensible capacity (W)	Water flow (l/h)	Heating capacity (W)
V1 - LS	89	102	591	492	56	655
V2	140	153	890	744	86	1004
V3 - MS	250	248	1440	1213	146	1696
V4	280	263	1513	1276	155	1795
V5 - HS	326	300	1743	1477	183	2123

2-pipe - In line I configuration - Circular return / discharge 1x200 mm - filter G3

Speeds	Air flow (m³/h)	Water flow (l/h)	Cooling mode (1)		Heating mode (2)
			Total capacity (W)	Sensible capacity (W)	Heating capacity (W)
V1 - LS	80	81	410	447	600
V2	130	127	738	698	950
V3 - MS	225	205	1189	1117	1561
V4	250	223	1296	1214	1711
V5 - HS	285	247	1436	1342	1912

4-pipe - In line I configuration - Circular return / discharge 1x200 mm - filter G3

Speeds	Air flow (m³/h)	Cooling mode (1)			Heating mode (3)	
		Water flow (l/h)	Total capacity (W)	Sensible capacity (W)	Water flow (l/h)	Heating capacity (W)
V1 - LS	78	79	459	436	50	577
V2	120	118	686	650	75	869
V3 - MS	210	196	1123	1056	125	1454
V4	235	212	1232	1157	138	1606
V5 - HS	275	241	1397	1306	159	1841

2-pipe - U configuration - Circular return / discharge 1x200 mm - without filter

Speeds	Air flow (m³/h)	Water flow (l/h)	Cooling mode (1)		Heating mode (2)
			Total capacity (W)	Sensible capacity (W)	Heating capacity (W)
V1 - LS	92	92	537	509	686
V2	155	149	864	816	1118
V3 - MS	270	237	1377	1288	1827
V4	300	257	1493	1393	1995
V5 - HS	348	287	1663	1544	2249

4-pipe - U configuration - Circular return / discharge 1x200 mm - without filter

Speeds	Air flow (m³/h)	Cooling mode (1)			Heating mode (3)	
		Water flow (l/h)	Total capacity (W)	Sensible capacity (W)	Water flow (l/h)	Heating capacity (W)
V1 - LS	90	91	526	499	57	662
V2	145	140	814	770	89	1038
V3 - MS	260	230	1337	1252	151	1754
V4	289	250	1451	1355	165	1920
V5 - HS	329	275	1598	1487	184	2139

For all tables, performance data based on:

(1) Cooling mode: Air: 27°C (bs) /19°C (bh), Chilled water: 7/12°C

(2) Heating mode: Air: 20°C, Entering water temperature: 50°C, water flow is the same as that in cooling mode

(3) Heating mode: Air: 20°C, Heating water: 70/60°C.

Values for 30Pa in MV

Performance Data - P-FD15

2-pipe - In line I configuration - Rectangular return / discharge - filter G2

Speeds	Air flow (m ³ /h)	Water flow (l/h)	Cooling mode (1)		Heating mode (2)
			Total capacity (W)	Sensible capacity (W)	Heating capacity (W)
V1 - LS	270	210	1230	1130	1600
V3 - MS	400	290	1700	1540	2260
V5 - HS	505	340	1900	1820	2790

4-pipe - In line I configuration - Rectangular return / discharge - filter G2

Speeds	Air flow (m ³ /h)	Cooling mode (1)			Heating mode (3)	
		Water flow (l/h)	Total capacity (W)	Sensible capacity (W)	Water flow (l/h)	Heating capacity (W)
V1 - LS	260	205	1190	1080	190	2230
V3 - MS	380	280	1610	1470	250	2850
V5 - HS	480	330	1920	1750	280	3220

2-pipe - In line I configuration - Circular return / discharge 1x200 mm - filter G2

Speeds	Air flow (m ³ /h)	Water flow (l/h)	Cooling mode (1)		Heating mode (2)
			Total capacity (W)	Sensible capacity (W)	Heating capacity (W)
V1 - LS	185	285	1128	137	1323
V3 - MS	272	246	1429	1293	1807
V5 - HS	366	301	1751	1544	2248

4-pipe - In line I configuration - Circular discharge / return 1x200 mm - filter G2

Speeds	Air flow (m ³ /h)	Cooling mode (1)			Heating mode (3)	
		Water flow (l/h)	Total capacity (W)	Sensible capacity (W)	Water flow (l/h)	Heating capacity (W)
V1 - LS	177	281	1106	1000	259	1846
V3 - MS	264	240	1396	1264	205	2342
V5 - HS	357	295	1721	1561	249	2834

2-pipe - U configuration - Circular discharge / return 1x200 mm - filter G2

Speeds	Air flow (m ³ /h)	Water flow (l/h)	Cooling mode (1)		Heating mode (2)
			Total capacity (W)	Sensible capacity (W)	Heating capacity (W)
V1 - LS	179	173	1008	934	1267
V3 - MS	244	232	1349	1213	1674
V5 - HS	361	299	1741	1533	2228

4-pipe - U configuration - Circular discharge / return 1x200 mm - filter G2

Speeds	Air flow (m ³ /h)	Cooling mode (1)			Heating mode (3)	
		Water flow (l/h)	Total capacity (W)	Sensible capacity (W)	Water flow (l/h)	Heating capacity (W)
V1 - LS	172	170	989	903	150	1709
V3 - MS	237	226	1318	1187	190	2164
V5 - HS	353	293	1712	1552	247	2810

For all tables, performance data based on:

(1) According to Eurovent - Cooling mode: Air: 27°C (bs) /19°C (bh), Chilled water: 7/12°C

(2) According to Eurovent - Heating mode: Air: 20°C, Entering water temperature: 50°C, water flow is the same as that in cooling mode

(3) According to Eurovent - Heating mode: Air: 20°C, Heating water: 70/60°C.

According to Eurovent 6/11 (Thermal test method), 6/10 (Airflow test method)

Performance Data - P-FD20

2-pipe - In line I configuration - Rectangular return / discharge - filter G2

Speeds	Air flow (m ³ /h)	Water flow (l/h)	Cooling mode (1)		Heating mode (2)
			Total capacity (W)	Sensible capacity (W)	Heating capacity (W)
V1 - LS	370	305	1720	1460	2410
V3 - MS	520	380	2230	1950	2930
V5 - HS	600	430	2460	2250	3100

4-pipe - In line I configuration - Rectangular return / discharge - filter G2

Speeds	Air flow (m ³ /h)	Cooling mode (1)			Heating mode (3)	
		Water flow (l/h)	Total capacity (W)	Sensible capacity (W)	Water flow (l/h)	Heating capacity (W)
V1 - LS	355	290	1670	1420	270	3170
V3 - MS	495	380	2190	1930	300	3460
V5 - HS	570	410	2390	2150	310	3540

2-pipe - In line I configuration - Circular return / discharge 1x200 mm - filter G2

Speeds	Air flow (m ³ /h)	Water flow (l/h)	Cooling mode (1)		Heating mode (2)
			Total capacity (W)	Sensible capacity (W)	Heating capacity (W)
V1 - LS	283	260	1515	1277	2083
V3 - MS	387	335	1956	1695	2558
V5 - HS	461	379	2208	1954	2820

4-pipe - In line I configuration - Circular discharge / return 1x200 mm - filter G2

Speeds	Air flow (m ³ /h)	Cooling mode (1)			Heating mode (3)	
		Water flow (l/h)	Total capacity (W)	Sensible capacity (W)	Water flow (l/h)	Heating capacity (W)
V1 - LS	270	254	1482	1248	180	2054
V3 - MS	380	332	1931	1669	223	2539
V5 - HS	449	376	2192	1936	244	2784

2-pipe - U configuration - Circular discharge / return 1x200 mm - filter G2

Speeds	Air flow (m ³ /h)	Water flow (l/h)	Cooling mode (1)		Heating mode (2)
			Total capacity (W)	Sensible capacity (W)	Heating capacity (W)
V1 - LS	224	228	1331	1113	1767
V3 - MS	313	301	1756	150	2199
V5 - HS	342	328	1911	1648	2307

4-pipe - U configuration - Circular discharge / return 1x200 mm - filter G2

Speeds	Air flow (m ³ /h)	Cooling mode (1)			Heating mode (3)	
		Water flow (l/h)	Total capacity (W)	Sensible capacity (W)	Water flow (l/h)	Heating capacity (W)
V1 - LS	217	224	1304	1089	154	1749
V3 - MS	305	298	1734	1478	193	2203
V5 - HS	339	326	1896	1633	201	2293

For all tables, performance data based on:

(1) According to Eurovent - Cooling mode: Air: 27°C (bs) /19°C (bh), Chilled water: 7/12°C

(2) According to Eurovent - Heating mode: Air: 20°C, Entering water temperature: 50°C, water flow is the same as that in cooling mode

(3) According to Eurovent - Heating mode: Air: 20°C, Heating water: 70/60°C.

According to Eurovent 6/11 (Thermal test method), 6/10 (Airflow test method)

Performance Data - P-FD25

2-pipe - In line I configuration - Rectangular return / discharge - filter G2

Speeds	Air flow (m ³ /h)	Water flow (l/h)	Cooling mode (1)		Heating mode (2)
			Total capacity (W)	Sensible capacity (W)	Heating capacity (W)
V1 - LS	440	420	2450	1990	3070
V3 - MS	550	480	2810	2280	3600
V5 - HS	640	565	3260	2690	4020

4-pipe - In line I configuration - Rectangular return / discharge - filter G2

Speeds	Air flow (m ³ /h)	Cooling mode (1)			Heating mode (3)	
		Water flow (l/h)	Total capacity (W)	Sensible capacity (W)	Water flow (l/h)	Heating capacity (W)
V1 - LS	420	380	2200	1760	310	3580
V3 - MS	525	470	2730	2200	365	4220
V5 - HS	610	520	3010	2460	390	4540

2-pipe - In line I configuration - Circular return / discharge 2x200 mm - filter G2

Speeds	Air flow (m ³ /h)	Water flow (l/h)	Cooling mode (1)		Heating mode (2)
			Total capacity (W)	Sensible capacity (W)	Heating capacity (W)
V1 - LS	369	369	2148	1666	2790
V3 - MS	418	411	2390	1899	3016
V5 - HS	527	481	2807	2239	3474

4-pipe - In line I configuration - Circular discharge / return 2x200 mm - filter G2

Speeds	Air flow (m ³ /h)	Cooling mode (1)			Heating mode (3)	
		Water flow (l/h)	Total capacity (W)	Sensible capacity (W)	Water flow (l/h)	Heating capacity (W)
V1 - LS	354	350	2039	1629	289	3287
V3 - MS	405	394	2295	1825	312	3561
V5 - HS	513	454	2646	2139	366	4171

2-pipe - U configuration - Circular discharge / return 1x200 mm - filter G2

Speeds	Air flow (m ³ /h)	Water flow (l/h)	Cooling mode (1)		Heating mode (2)
			Total capacity (W)	Sensible capacity (W)	Heating capacity (W)
V1 - LS	360	364	2121	1644	2734
V3 - MS	408	404	2357	1872	2964
V5 - HS	496	468	2725	2163	3325

4-pipe - U configuration - Circular discharge / return 1x200 mm - filter G2

Speeds	Air flow (m ³ /h)	Cooling mode (1)			Heating mode (3)	
		Water flow (l/h)	Total capacity (W)	Sensible capacity (W)	Water flow (l/h)	Heating capacity (W)
V1 - LS	334	338	1971	1572	276	3152
V3 - MS	394	371	2163	1737	307	3495
V5 - HS	474	433	2526	2040	346	3949

For all tables, performance data based on:

(1) According to Eurovent - Cooling mode: Air: 27°C (bs) /19°C (bh), Chilled water: 7/12°C

(2) According to Eurovent - Heating mode: Air: 20°C, Entering water temperature: 50°C, water flow is the same as that in cooling mode

(3) According to Eurovent - Heating mode: Air: 20°C, Heating water: 70/60°C.

According to Eurovent 6/11 (Thermal test method), 6/10 (Airflow test method)

Performance Data - P-FD30

2-pipe - In line I configuration - Rectangular return / discharge - filter G2

Speeds	Air flow (m ³ /h)	Water flow (l/h)	Cooling mode (1)		Heating mode (2)
			Total capacity (W)	Sensible capacity (W)	Heating capacity (W)
V1 - LS	300	327	1900	1420	3790
V2	536	496	2880	220	5930
V3 - MS	738	630	3660	2820	7620
V4	945	753	4370	3360	9110
V5 - HS	1068	827	4800	3680	10000

4-pipe - In line I configuration - Rectangular return / discharge - filter G2

Speeds	Air flow (m ³ /h)	Cooling mode (1)			Heating mode (3)	
		Water flow (l/h)	Total capacity (W)	Sensible capacity (W)	Water flow (l/h)	Heating capacity (W)
V1 - LS	255	296	1720	1240	149	1730
V2	468	463	2690	1970	220	2550
V3 - MS	654	610	3540	2610	282	3270
V4	846	729	4230	3130	329	3820
V5 - HS	943	787	4570	3390	353	4100

2-pipe - In line I configuration - Circular return / discharge 2x200 mm - filter G2

Speeds	Air flow (m ³ /h)	Water flow (l/h)	Cooling mode (1)		Heating mode (2)
			Total capacity (W)	Sensible capacity (W)	Heating capacity (W)
V1 - LS	251	291	1690	1260	3350
V2	491	463	2690	2050	5530
V3 - MS	687	599	3480	2680	7250
V4	880	715	4150	3190	8640
V5 - HS	984	777	4510	3460	9390

4-pipe - In line I configuration - Circular return / discharge 2x200 mm - filter G2

Speeds	Air flow (m ³ /h)	Cooling mode (1)			Heating mode (3)	
		Water flow (l/h)	Total capacity (W)	Sensible capacity (W)	Water flow (l/h)	Heating capacity (W)
V1 - LS	211	262	1520	1090	134	1560
V2	429	434	2520	1840	207	2400
V3 - MS	613	579	3360	2470	268	3110
V4	793	698	4050	2990	316	3380
V5 - HS	879	749	4350	3220	337	3330

2-pipe - U configuration - Circular return / discharge 1x200 mm - filter G2

Speeds	Air flow (m ³ /h)	Water flow (l/h)	Cooling mode (1)		Heating mode (2)
			Total capacity (W)	Sensible capacity (W)	Heating capacity (W)
V1 - LS	197	253	1470	1080	2870
V2	354	365	2120	1600	4280
V3 - MS	501	470	2730	2090	5610
V4	659	582	3380	2600	7030
V5 - HS	684	598	3470	2670	7220

4-pipe - U configuration - Circular return / discharge 1x200 mm - filter G2

Speeds	Air flow (m ³ /h)	Cooling mode (1)			Heating mode (3)	
		Water flow (l/h)	Total capacity (W)	Sensible capacity (W)	Water flow (l/h)	Heating capacity (W)
V1 - LS	176	234	1360	970	123	1430
V2	326	351	2040	1480	172	2000
V3 - MS	468	463	2690	1970	220	2550
V4	620	584	3390	2490	270	3140
V5 - HS	639	598	3470	2560	276	3210

For all tables, performance data based on:

(1) According to Eurovent - Cooling mode: Air: 27°C (bs) /19°C (bh), Chilled water: 7/12°C

(2) According to Eurovent - Heating mode: Air: 20°C, Entering water temperature: 50°C, water flow is the same as that in cooling mode

(3) According to Eurovent - Heating mode: Air: 20°C, Heating water: 70/60°C.

According to Eurovent 6/11 (Thermal test method), 6/10 (Airflow test method)

Performance Data - P-FD40

2-pipe - In line I configuration - Rectangular return / discharge - filter G3

Speeds	Air flow (m ³ /h)	Water flow (l/h)	Cooling mode (1)		Heating mode (2)
			Total capacity (W)	Sensible capacity (W)	Heating capacity (W)
V1 - LS	362	400	2324	1992	3075
V2	660	679	3945	3406	5195
V3 - MS	877	854	4958	4307	6505
V4	1090	1002	5816	5086	7599
V5 - HS	1392	1171	6801	6012	8826

4-pipe - In line I configuration - Rectangular return / discharge - filter G3

Speeds	Air flow (m ³ /h)	Cooling mode (1)			Heating mode (3)	
		Water flow (l/h)	Total capacity (W)	Sensible capacity (W)	Water flow (l/h)	Heating capacity (W)
V1 - LS	350	399	2253	1931	279	3235
V2	613	638	3707	3197	430	4996
V3 - MS	812	804	4669	4049	512	5946
V4	1008	948	5502	4799	565	6559
V5 - HS	1240	1092	6339	5573	592	6872

2-pipe - In line I configuration - Circular return / discharge 1x200 mm - filter G3

Speeds	Air flow (m ³ /h)	Water flow (l/h)	Cooling mode (1)		Heating mode (2)
			Total capacity (W)	Sensible capacity (W)	Heating capacity (W)
V1 - LS	316	355	2060	1663	2608
V2	575	611	3545	2901	4494
V3 - MS	777	791	4589	3799	5824
V4	950	929	5393	4511	6851
V5 - HS	1191	1099	6379	5423	8119

4-pipe - In line I configuration - Circular return / discharge 1x200 mm - filter G3

Speeds	Air flow (m ³ /h)	Cooling mode (1)			Heating mode (3)	
		Water flow (l/h)	Total capacity (W)	Sensible capacity (W)	Water flow (l/h)	Heating capacity (W)
V1 - LS	348	348	2017	1628	251	2909
V2	564	564	3277	2674	385	4471
V3 - MS	754	754	4377	3614	483	5613
V4	900	900	5223	4359	542	6298
V5 - HS	1054	1054	6120	5179	583	6771

2-pipe - U configuration - Circular return / discharge 1x200 mm - without filter

Speeds	Air flow (m ³ /h)	Water flow (l/h)	Cooling mode (1)		Heating mode (2)
			Total capacity (W)	Sensible capacity (W)	Heating capacity (W)
V1 - LS	200	230	1335	1072	1688
V2	357	398	2308	1867	2922
V3 - MS	457	498	2894	2353	3665
V4	570	607	3521	2883	4466
V5 - HS	662	691	4011	3298	5087

4-pipe - U configuration - Circular return / discharge 1x200 mm - without filter

Speeds	Air flow (m ³ /h)	Cooling mode (1)			Heating mode (3)	
		Water flow (l/h)	Total capacity (W)	Sensible capacity (W)	Water flow (l/h)	Heating capacity (W)
V1 - LS	198	228	1322	1061	168	1956
V2	328	367	2133	1723	264	3062
V3 - MS	449	491	2848	2315	342	3966
V4	557	595	3453	2823	402	4669
V5 - HS	640	671	3897	3200	443	5144

For all tables, performance data based on:

(1) According to Eurovent - Cooling mode: Air: 27°C (bs) /19°C (bh), Chilled water: 7/12°C

(2) According to Eurovent - Heating mode: Air: 20°C, Entering water temperature: 50°C, water flow is the same as that in cooling mode

(3) According to Eurovent - Heating mode: Air: 20°C, Heating water: 70/60°C.

According to Eurovent 6/11 (Thermal test method), 6/10 (Airflow test method)

2-pipe system

Models	Fan speed	Air flow (m ³ /h)	External static pressure (Pa)	Cooling mode			Heating mode		Electric capacity (W)	Sound power levels	
				Total capacity (kW)	Sensible capacity (kW)	Water pressure drop (kPa)	Heating capacity (kW)	Water pressure drop (kPa)		Return + Radiated dB(A)	Discharge dB(A)
P-FD10	LS	125	19	0.81	0.67	1	0.92	1	7	33	32
	MS	200	50	1.21	1.01	3	1.41	3	18	41	40
	HS	218	59	1.29	1.09	3	1.52	3	23	43	42
P-FD15	LS	270	19	1.23	1.13	4	1.60	4	8	44	45
	MS	400	50	1.70	1.54	7	2.26	7	30	52	56
	HS	505	80	1.97	1.82	9	2.79	9	60	60	62
P-FD20	LS	370	26	1.70	1.46	8	2.41	8	18	46	48
	MS	520	50	2.23	1.95	13	2.93	13	47	54	57
	HS	600	66	2.46	2.25	15	3.10	15	72	58	61
P-FD25	LS	455	32	2.45	1.99	16	3.07	16	26	50	50
	MS	550	50	2.81	2.28	21	3.60	21	41	55	56
	HS	640	66	3.26	2.69	28	4.02	28	64	61	61
P-FD30	LS	300	8.3	1.9	1.42	15.2	1.9	10.3	9	40	36
	MS	738	50	3.6	2.82	44	3.83	37.6	65	58	56
	HS	1068	105	4.8	3.68	70.3	5.01	62.8	163	64	64
P-FD40	LS	362	7	2.32	1.99	7	3.08	7	10	45	38
	MS	877	50	4.96	4.31	27	6.51	27	65	51	59
	HS	1090	72	5.82	5.09	36	7.6	36	114	57	64

Performance data based on:

- Cooling mode: Air: 27 °C (dry bulb) / 19 °C (wet bulb) - Chilled water: 7/12 °C.
- Heating mode: Air: 20 °C - Entering water temperature: 50 °C, water flow identical to chilled water flow.
- According to Eurovent 6/11 (Thermal test method), 6/10 (Airflow test method) and 8/12 (Sound test method).
- Configuration: Rectangular return / Rectangular discharge.

4-pipe system

Models	Fan speed	Air flow (m ³ /h)	External static pressure (Pa)	Cooling mode			Heating mode		Electric capacity (W)	Sound power levels	
				Total capacity (kW)	Sensible capacity (kW)	Water pressure drop (kPa)	Heating capacity (kW)	Water pressure drop (kPa)		Return + Radiated dB(A)	Discharge dB(A)
P-FD10	LS	106	18	0.69	0.58	1	0.77	3	7	31	30
	MS	180	50	1.11	0.93	2	1.27	7	18	39	38
	HS	195	57	1.18	0.99	3	1.36	8	22	41	40
P-FD15	LS	265	18	1.19	1.08	4	2.23	6	8	44	45
	MS	380	50	1.61	1.47	7	2.85	9	30	52	56
	HS	480	72	1.92	1.75	9	3.22	12	60	60	62
P-FD20	LS	360	25	1.67	1.42	8	3.17	11	18	46	48
	MS	507	50	2.19	1.93	13	3.46	14	47	54	57
	HS	575	64	2.39	2.15	15	3.54	15	72	58	61
P-FD25	LS	410	31	2.22	1.76	13	3.58	15	26	50	50
	MS	525	50	2.73	2.20	20	4.22	21	41	55	56
	HS	595	65	3.01	2.46	23	4.54	24	69	61	61
P-FD30	LS	256	7.6	1.72	1.24	8.59	1.73	3.27	8	40	36
	MS	654	50	3.54	2.61	32.4	3.27	12.3	60	58	56
	HS	943	104	4.57	3.39	52.7	4.1	19.6	147	64	64
P-FD40	LS	350	6	2.25	1.93	7	3.24	2	10	45	38
	MS	812	50	4.67	4.05	24	5.95	16	62	50	57
	HS	1008	77	5.5	4.8	31	6.56	18	108	55	62

Performance data based on:

- Cooling mode: Air: 27 °C (dry bulb) / 19 °C (wet bulb) - Chilled water: 7/12 °C.
- Heating mode: Air: 20 °C - Heating water: 70/60°C.
- According to Eurovent 6/11 (Thermal test method), 6/10 (Airflow test method) and 8/12 (Sound test method).
- Configuration: Rectangular return / Rectangular discharge.

Water Pressure Drop Curves

2-pipe units - Cooling coil

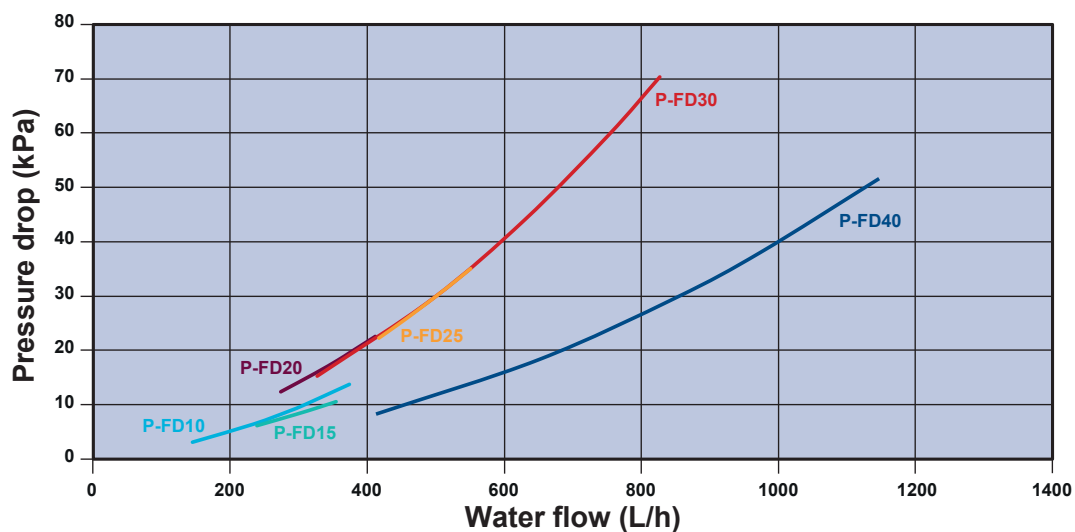

4-pipe units - Heating coil

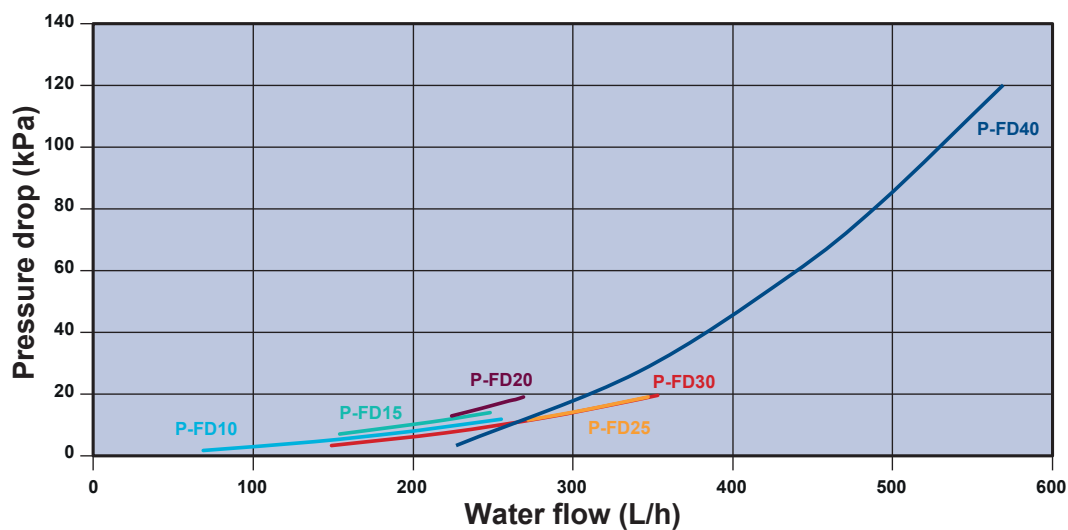

Dimensions

P-FD EC with one Ø200 mm Circular Duct Collars - "I" Configuration

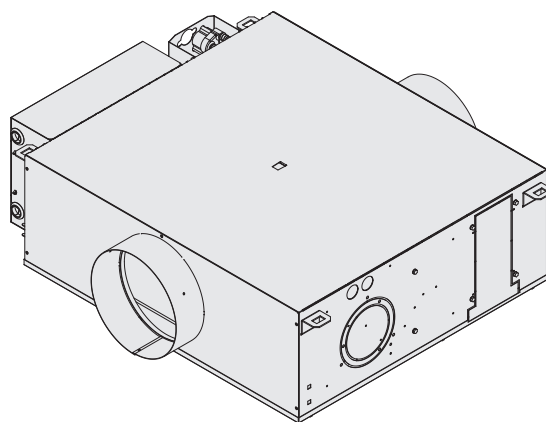
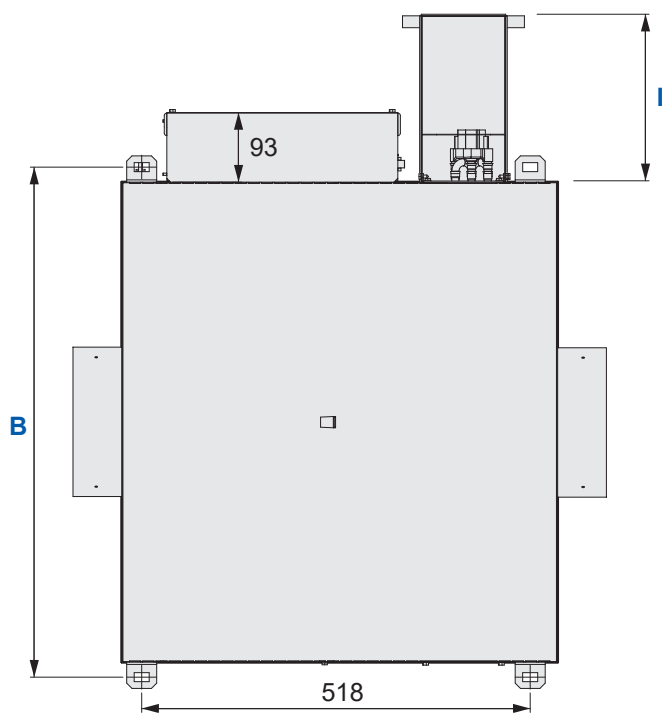
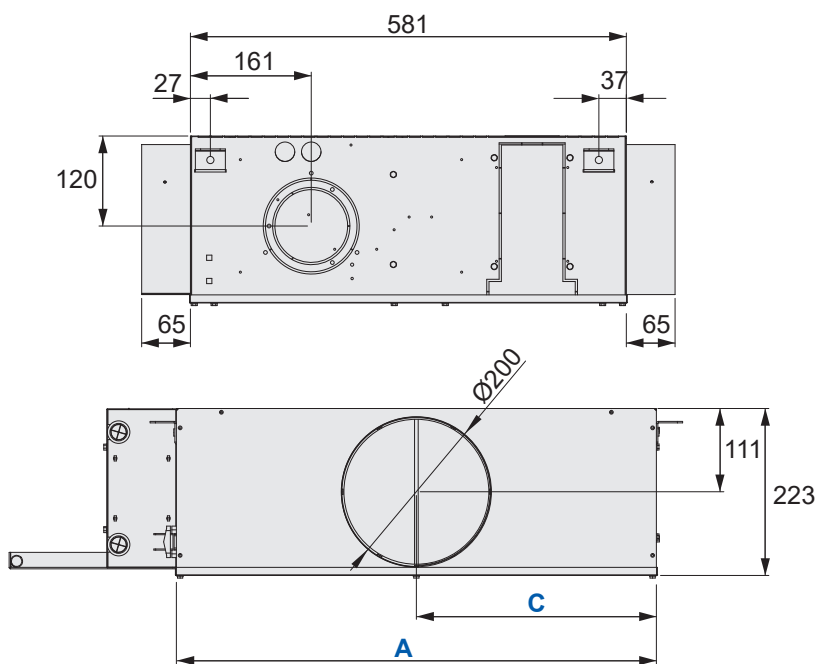

	A	B	C	I
P-FD10	mm 540	580	270	256
P-FD15	mm 640	680	320	223
P-FD20	mm 740	780	370	223

Dimensions (continued)

P-FD EC with two Ø200 mm Circular Duct Collars - "I" Configuration

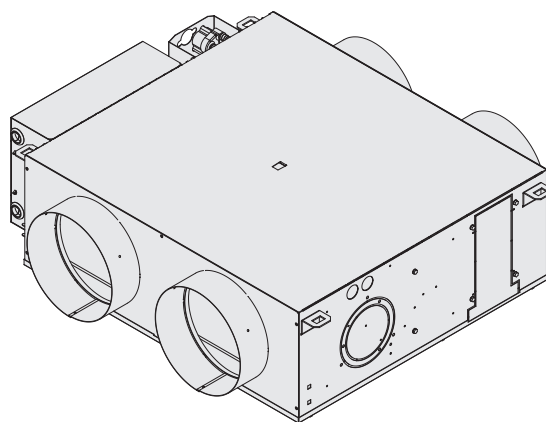
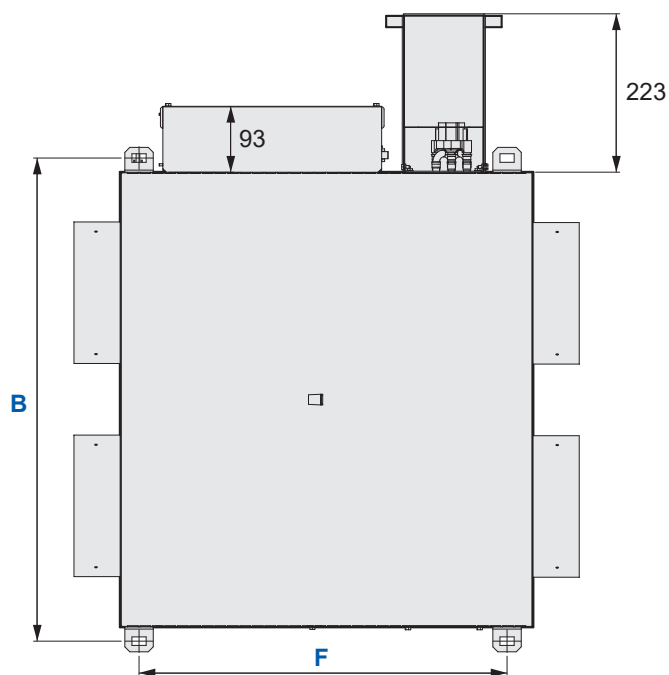
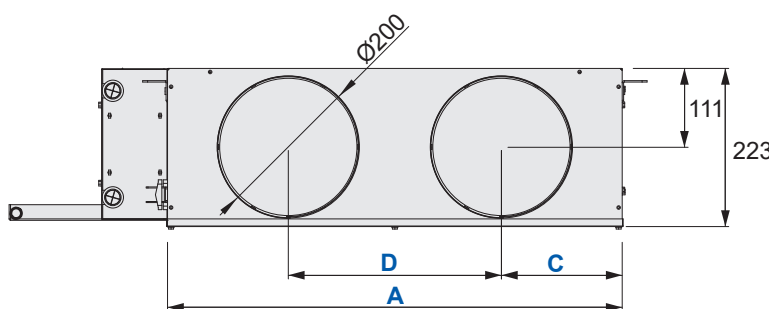
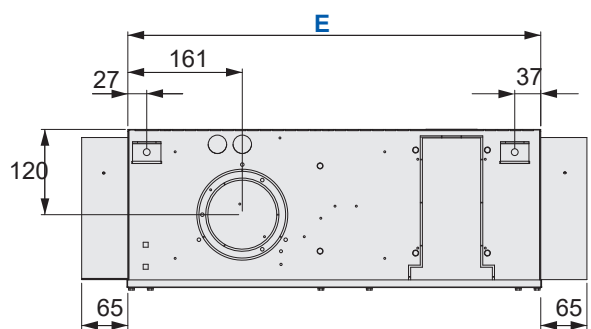

		A	B	C	D	E	F
P-FD15	mm	640	680	170	300	581	518
P-FD20	mm	740	780	195	350	581	518
P-FD25/P-FD30	mm	840	880	210	420	581	518

Dimensions (continued)

P-FD EC with three Ø200 mm Circular Duct Collars - "I" Configuration

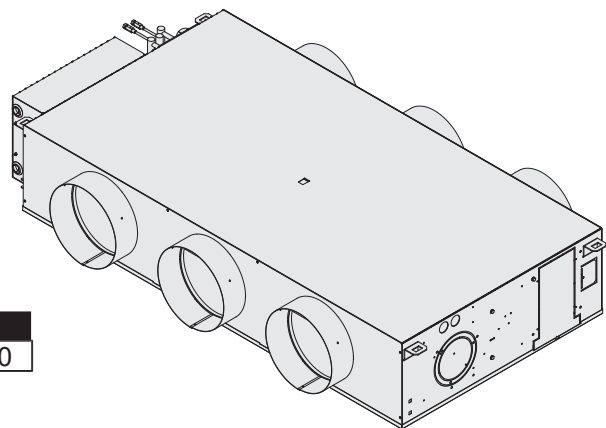
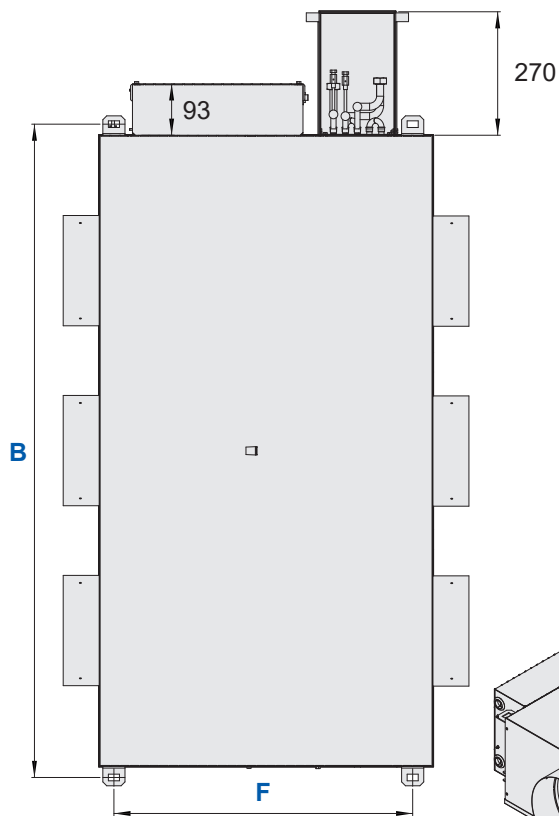
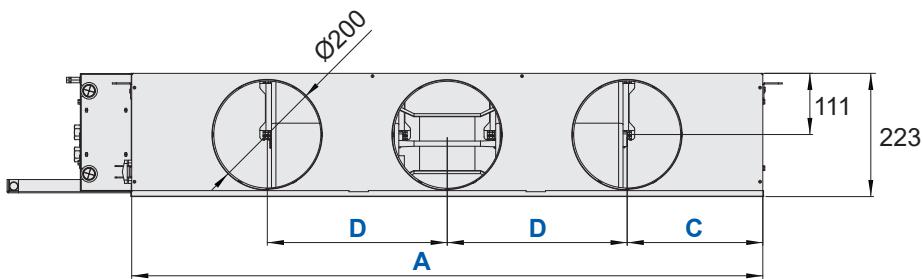
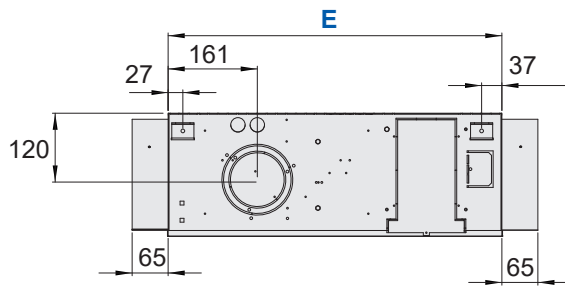

	A	B	C	D	E	F	
P-FD40	mm	1140	1180	245	325	603	540

Dimensions (continued)

P-FD EC with Rectangular Inlet and Outlet - "I" Configuration

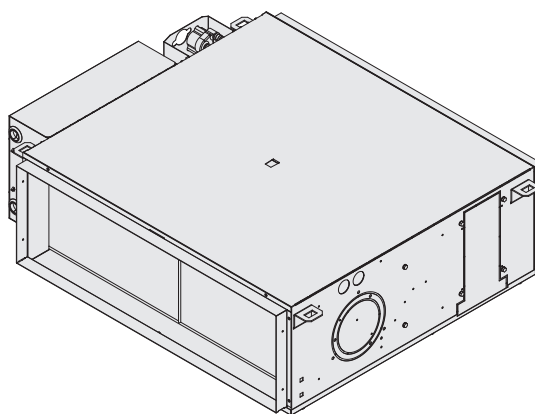
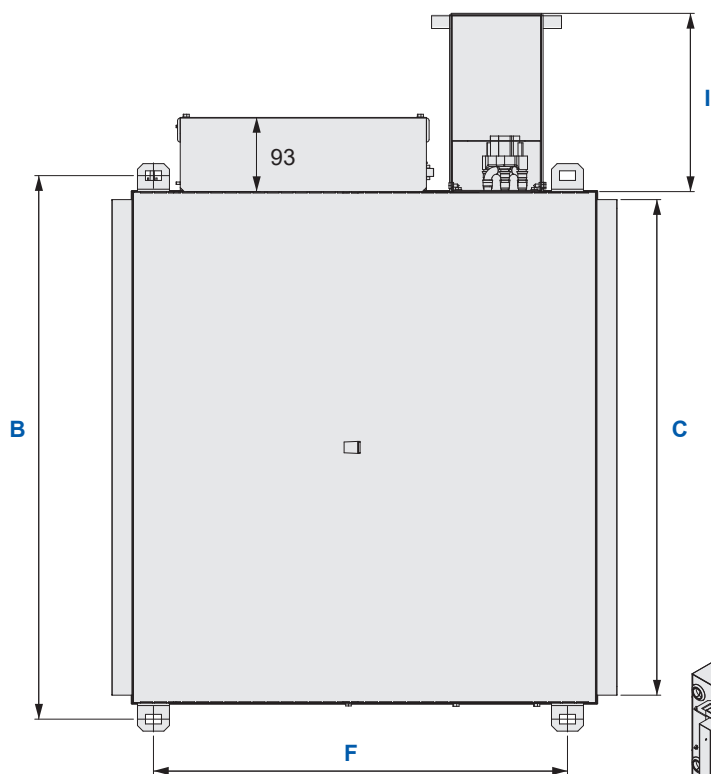
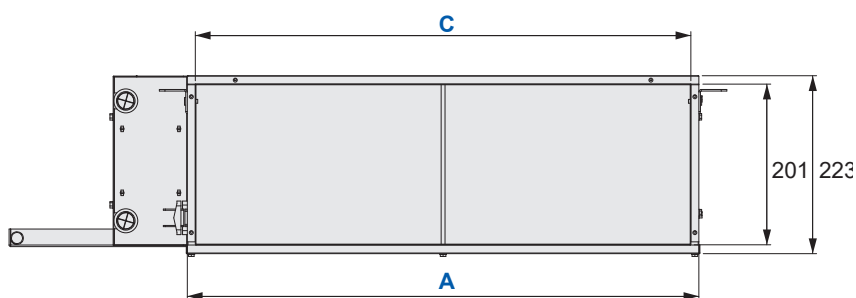
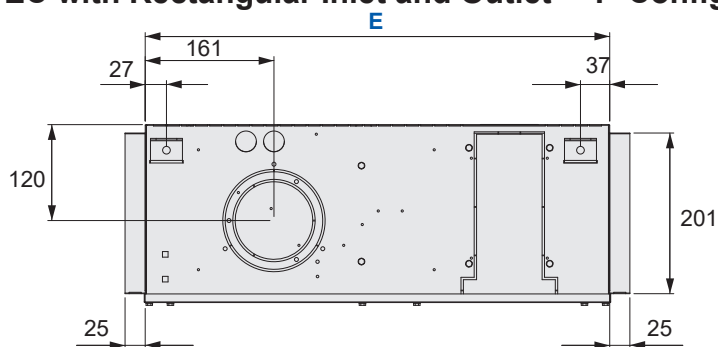

		A	B	C	E	F	I
P-FD10	mm	540	580	520	581	518	256
P-FD15	mm	640	680	620	581	518	223
P-FD20	mm	740	780	720	581	518	223
P-FD25/P-FD30	mm	840	880	820	581	518	223
P-FD40	mm	1140	1180	1120	603	540	270

Dimensions (continued)

P-FD EC with one Ø200 mm Circular Duct Collars - "J" Configuration

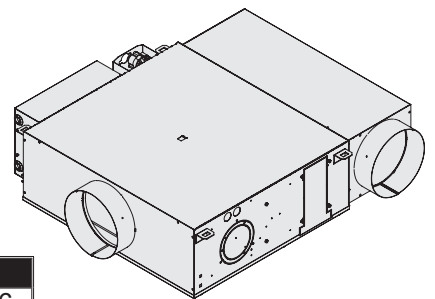
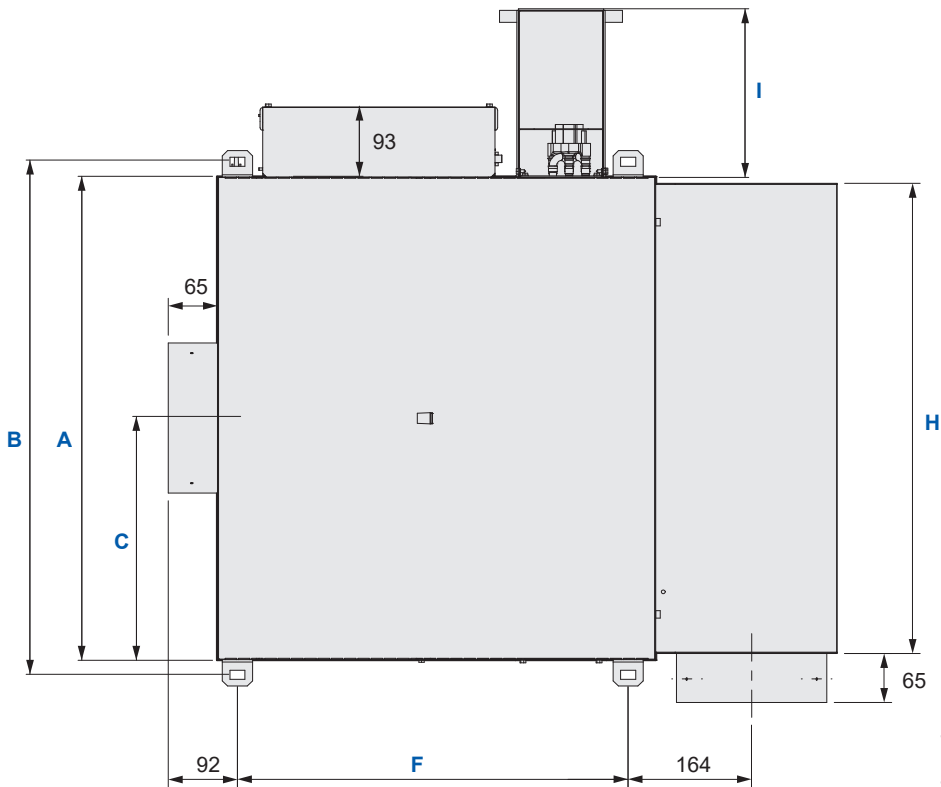
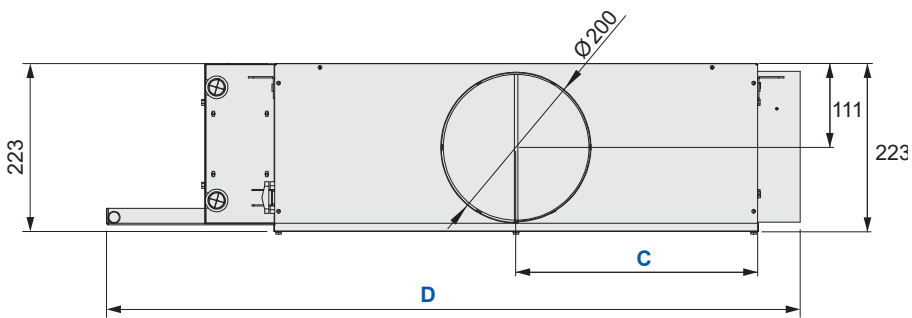
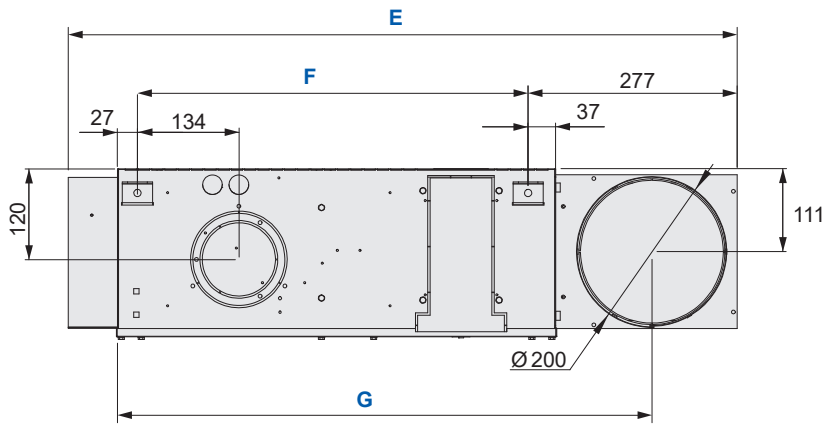

	A	B	C	D	E	F	G	H	I	
P-FD10	mm	540	580	270	820	887	518	709	523	256
P-FD15	mm	640	680	320	920	887	518	709	623	223
P-FD20	mm	740	780	370	1020	887	518	709	723	223
P-FD25/P-FD30	mm	840	880	420	1120	887	518	709	823	223

Dimensions (continued)

P-FD EC with three Ø200 mm Circular Duct Collars - "J" Configuration

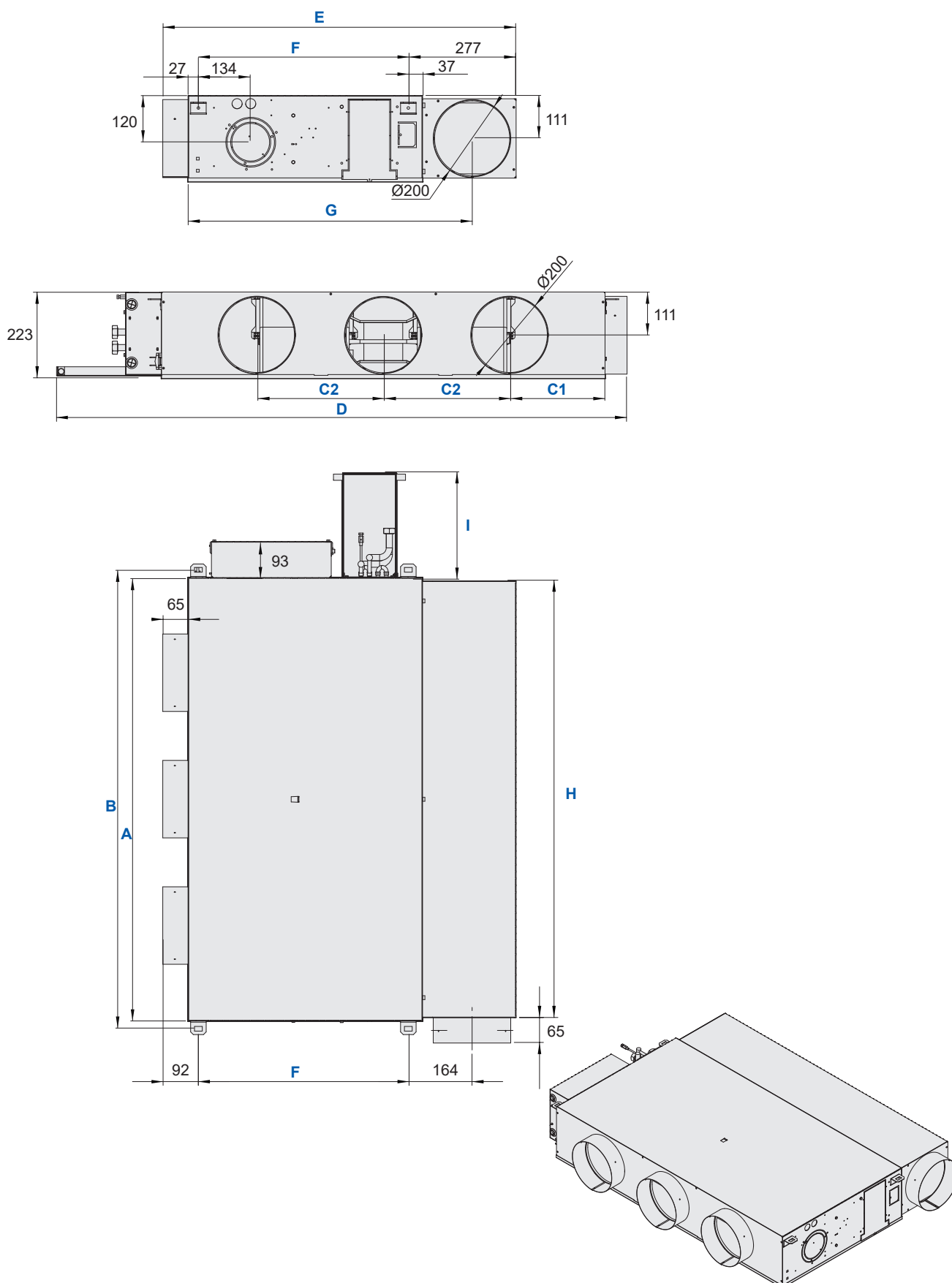

	A	B	C1	C2	D	E	F	G	H	I	
P-FD40	mm	1140	1180	245	325	1420	909	540	731	1123	270

Dimensions (continued)

P-FD EC with one Ø200 mm Circular Duct Collars - "L" Configuration

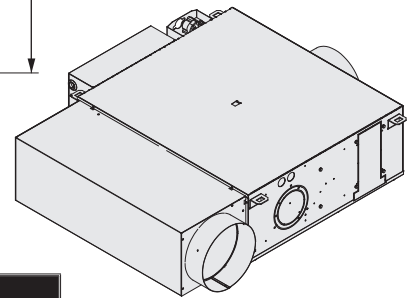
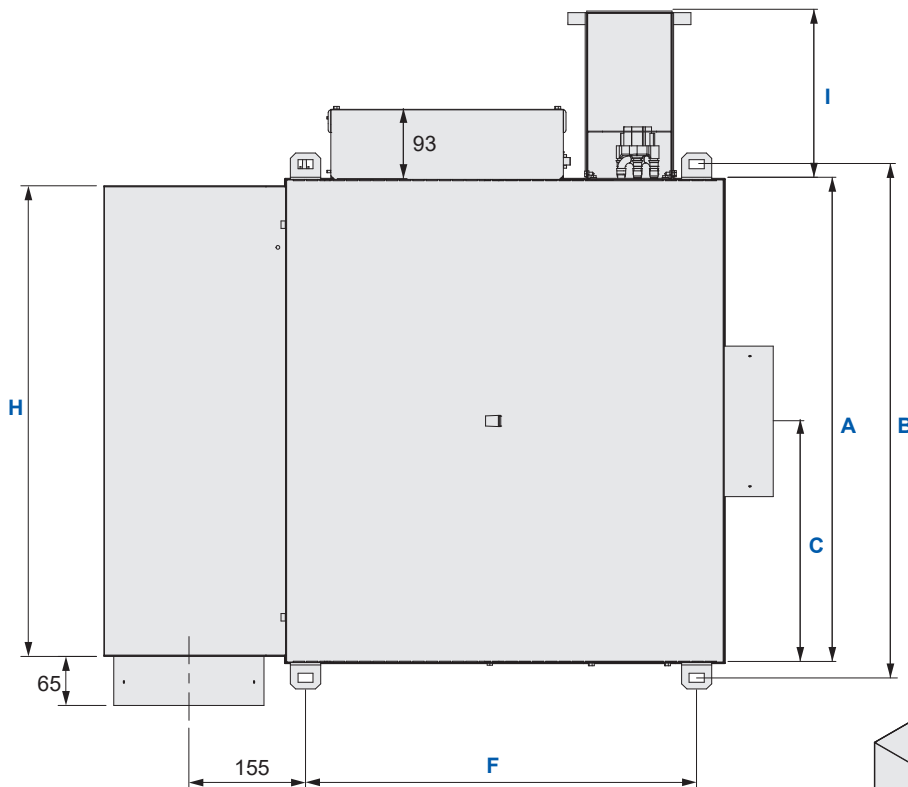
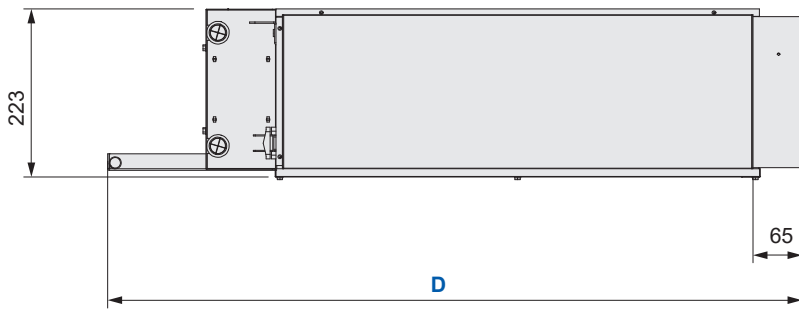
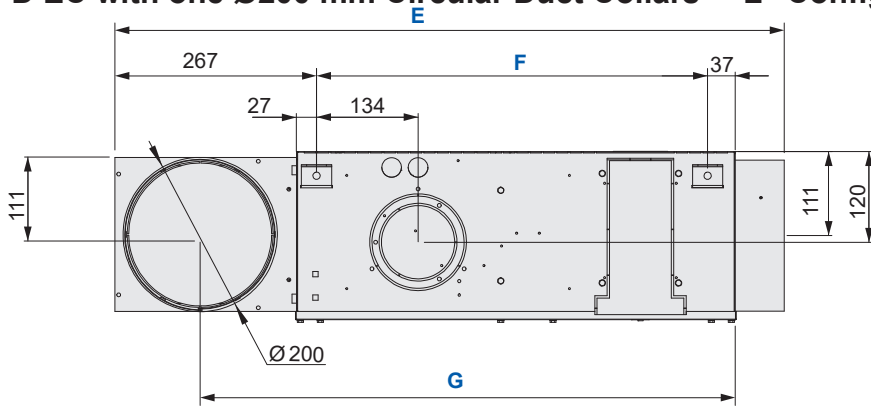

		A	B	C	D	E	F	G	H	I
P-FD10	mm	540	580	270	820	887	518	709	523	256
P-FD15	mm	640	680	320	920	887	518	709	623	223
P-FD20	mm	740	780	370	1020	887	518	709	723	223
P-FD25/P-FD30	mm	840	880	420	1120	887	518	709	823	223

Dimensions (continued)

P-FD EC with three Ø200 mm Circular Duct Collars - "L" Configuration

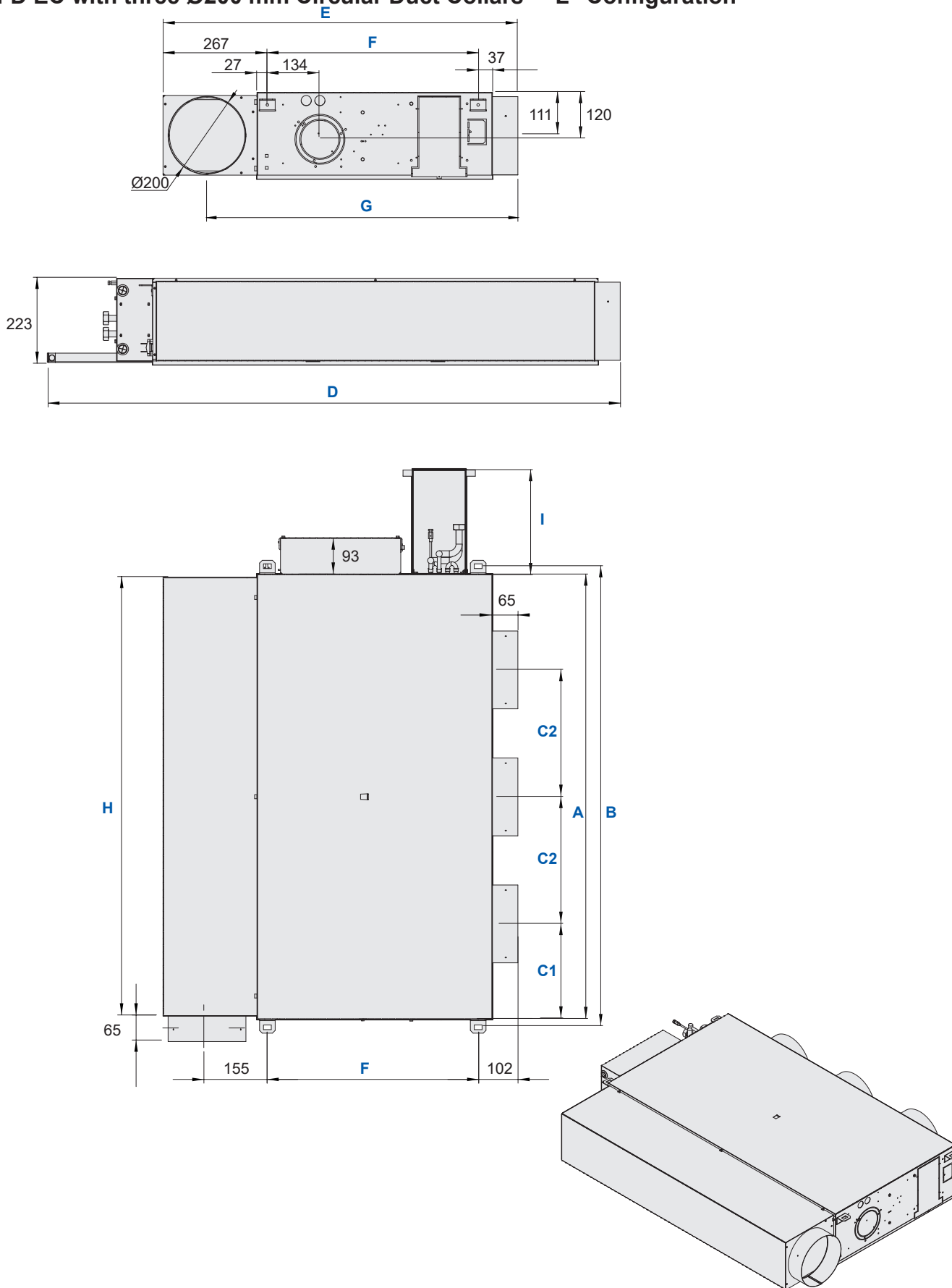

	A	B	C1	C2	D	E	F	G	H	I	
P-FD40	mm	1140	1180	245	325	1420	909	540	731	1123	270

Dimensions (continued)

P-FD EC with Ø200 mm Circular Duct Collars - "U" Configuration

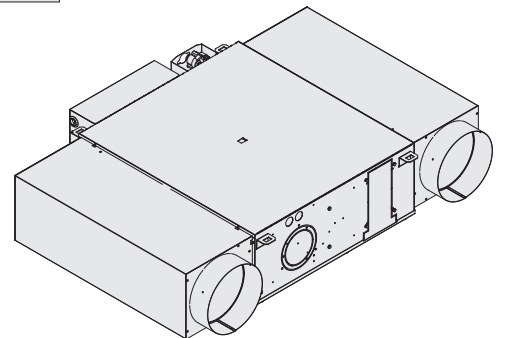
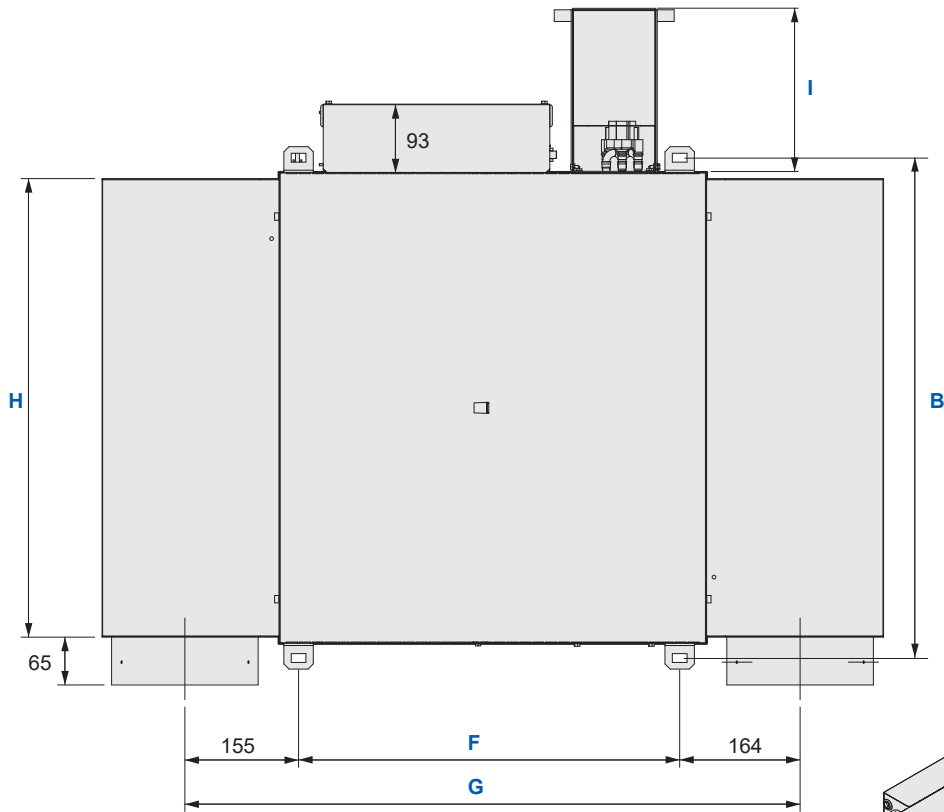
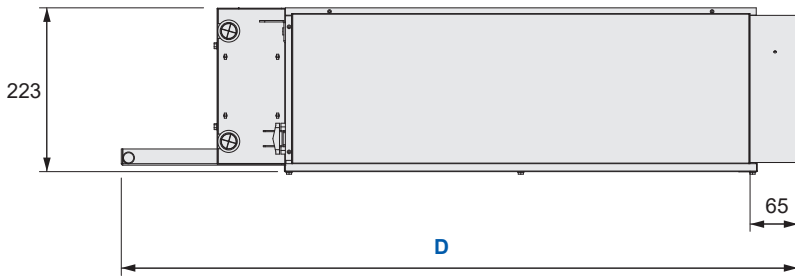
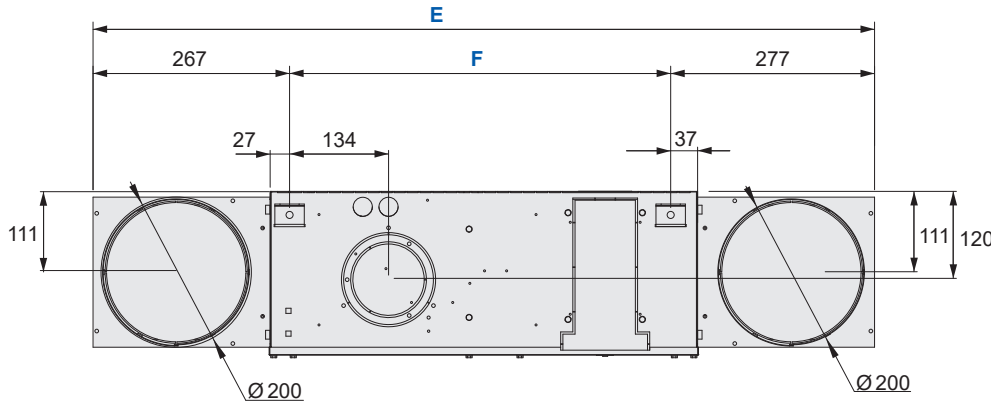

		B	D	E	F	G	H	I
P-FD10	mm	580	820	1062	518	836	523	256
P-FD15	mm	680	920	1062	518	836	623	223
P-FD20	mm	780	1020	1062	518	836	723	223
P-FD25/P-FD30	mm	880	1120	1062	518	836	823	223
P-FD40	mm	1180	1420	1084	540	859	1123	270

Dimensions - Water Connections

P-FD10

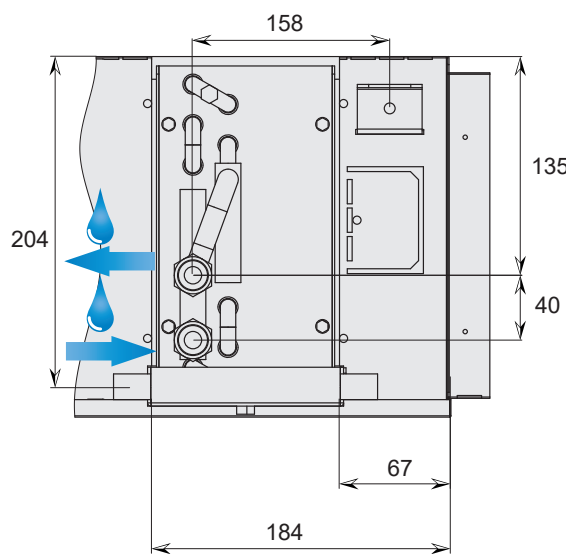
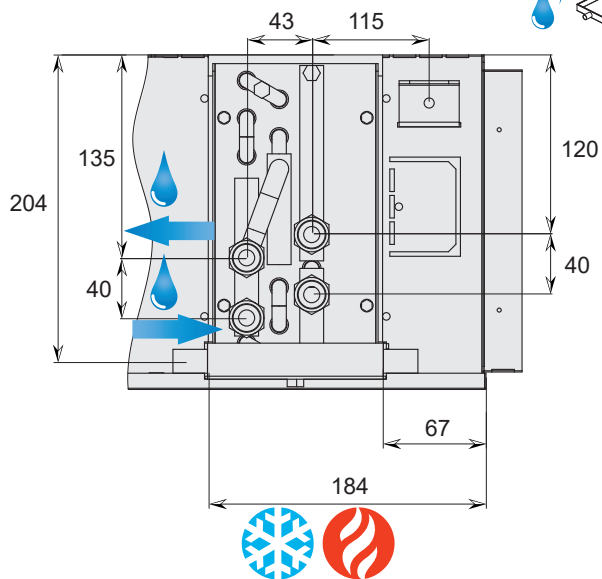
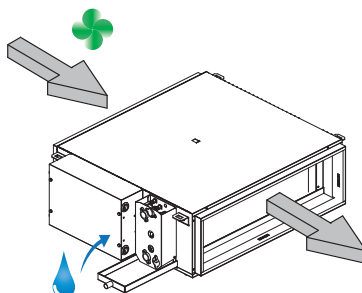
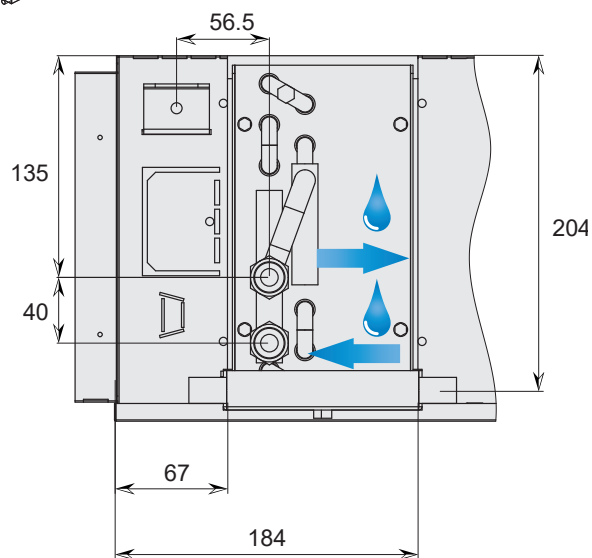
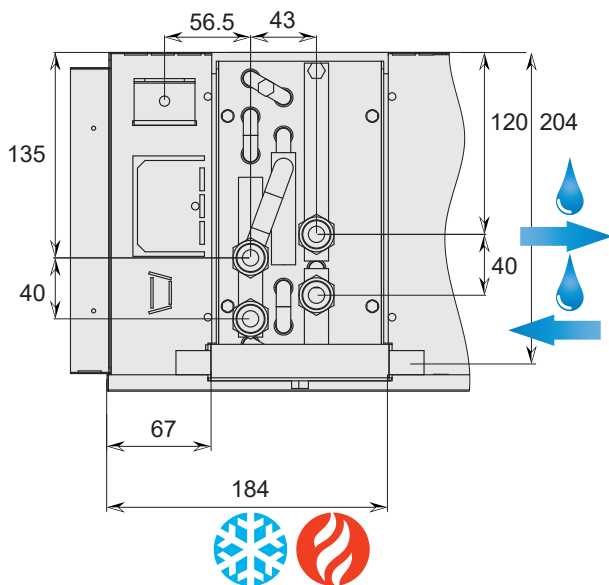
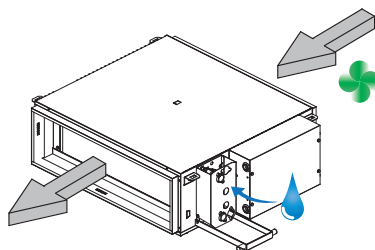

Dimensions - Water Connections (continued)

P-FD15 - P-FD20 - P-FD25 - P-FD30

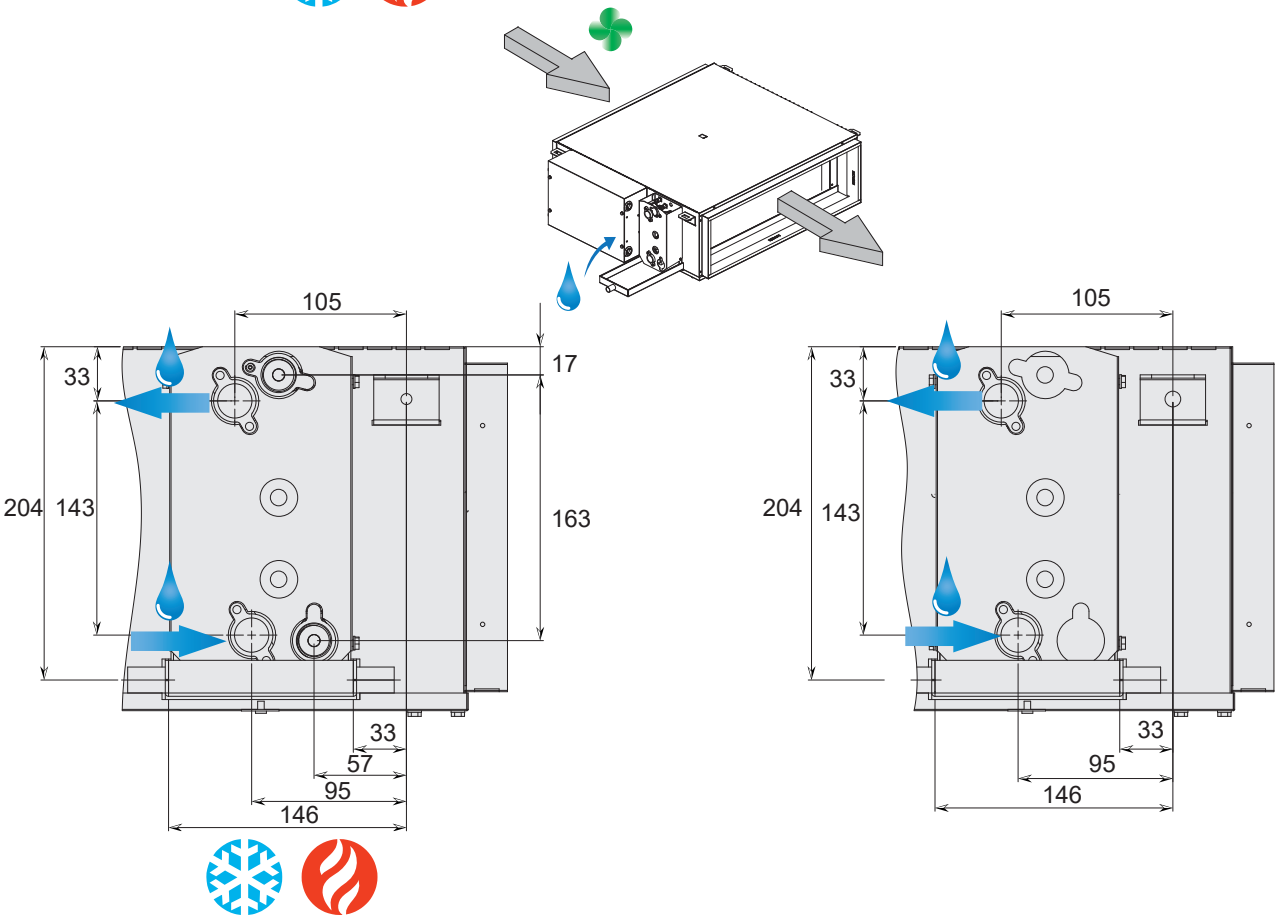
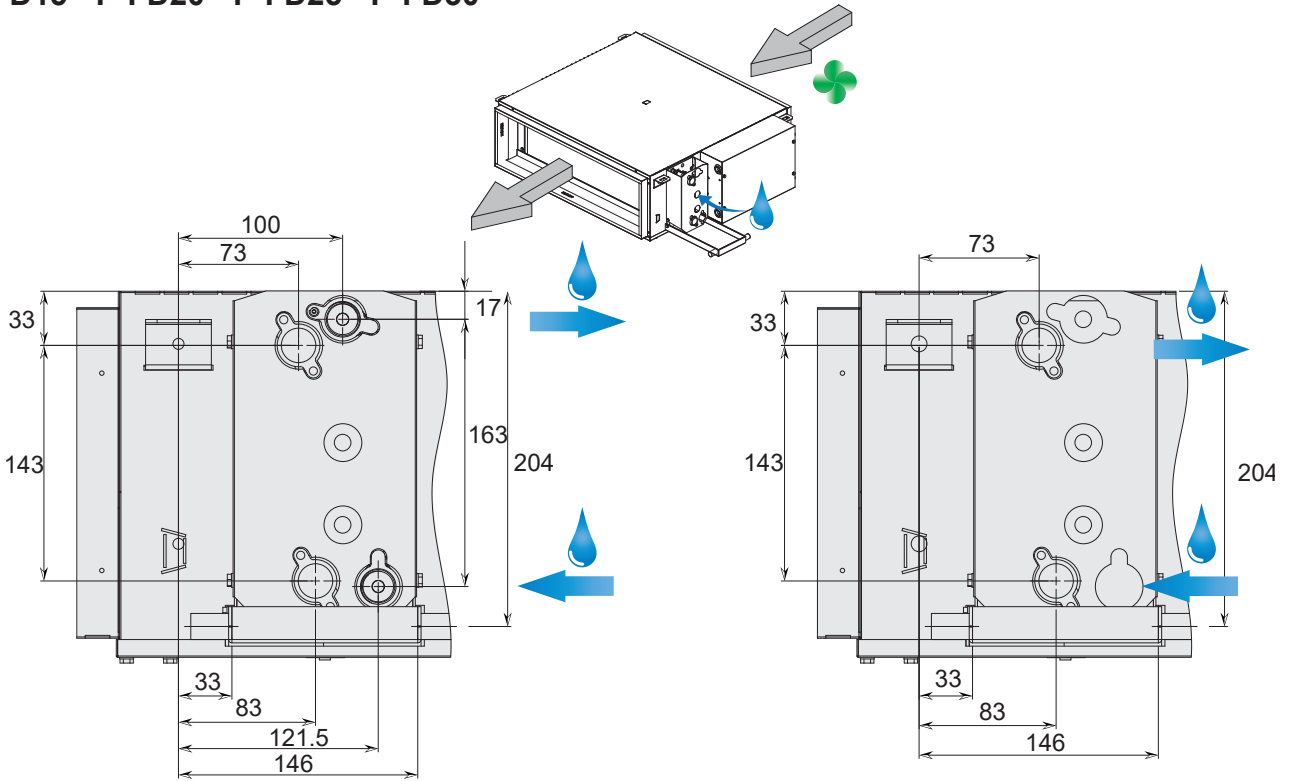

Dimensions - Water Connections (continued)

P-FD40

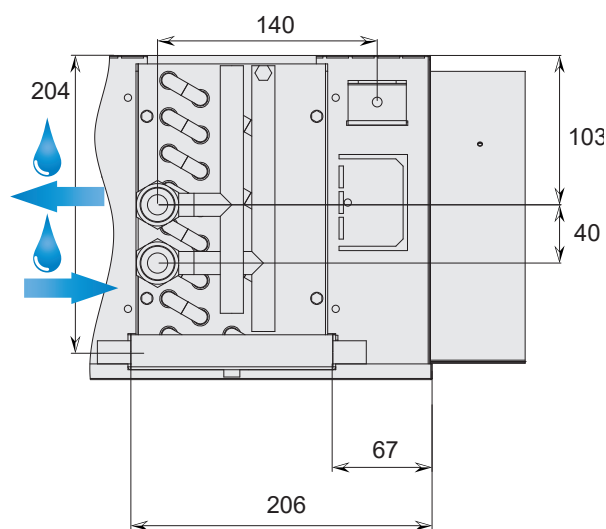
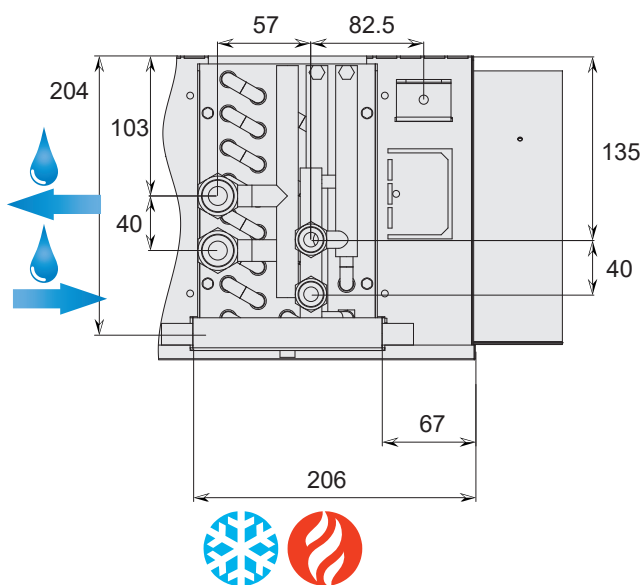
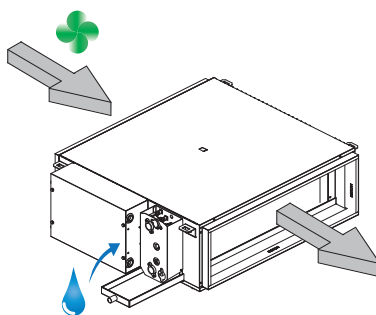
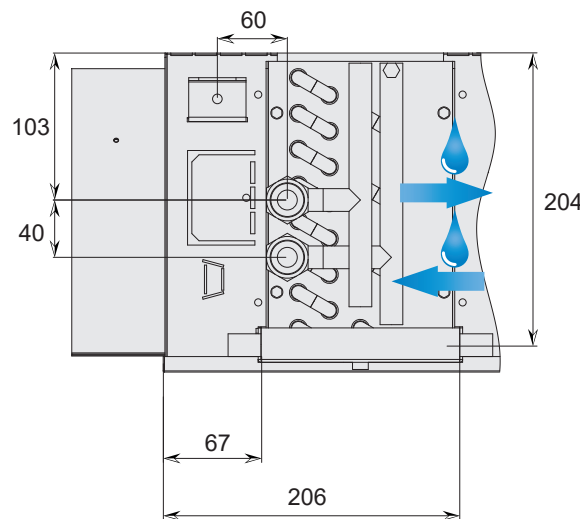
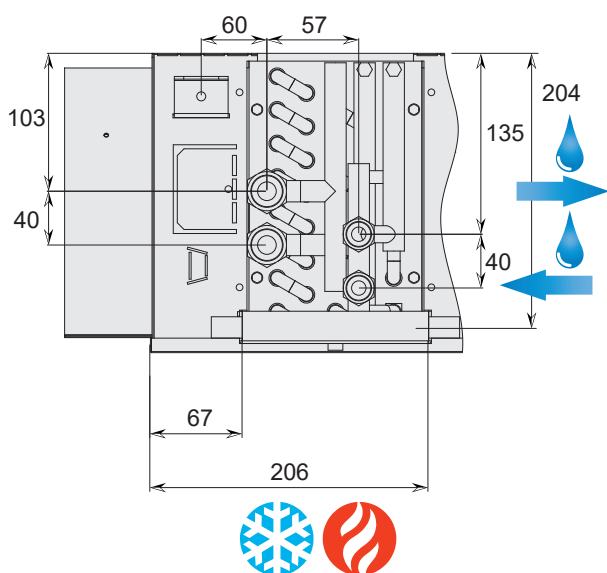
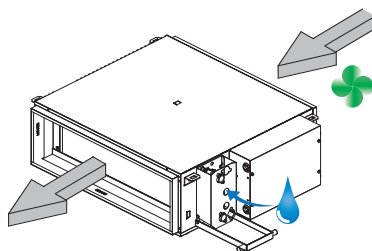

Definition of the Service Sides

The service side is defined by the position of the water connections when facing front of air flow.

RIGHT-HAND service side for water and electrical connections - "I" configuration

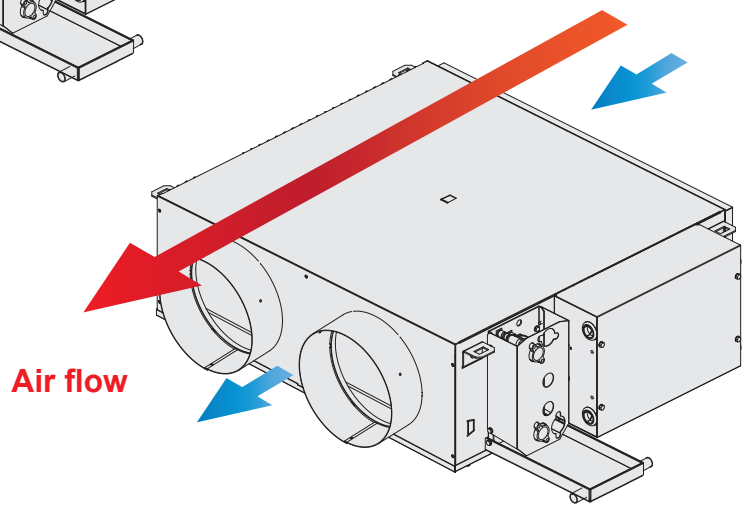
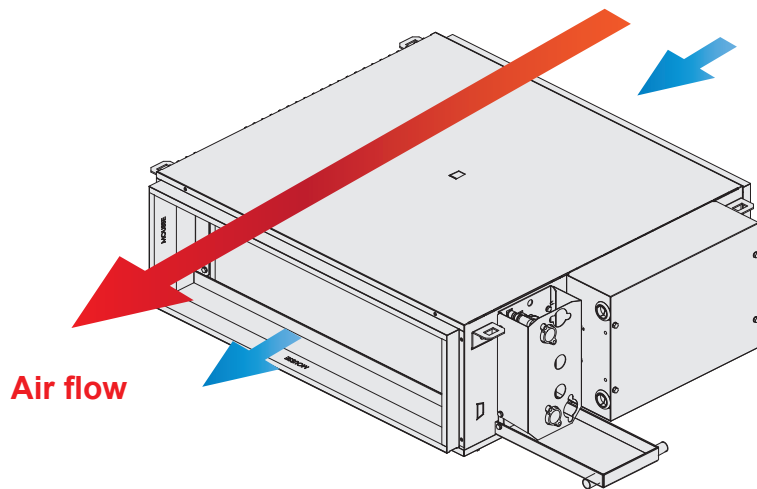

RIGHT-HAND service side for water and electrical connections - "U" configuration

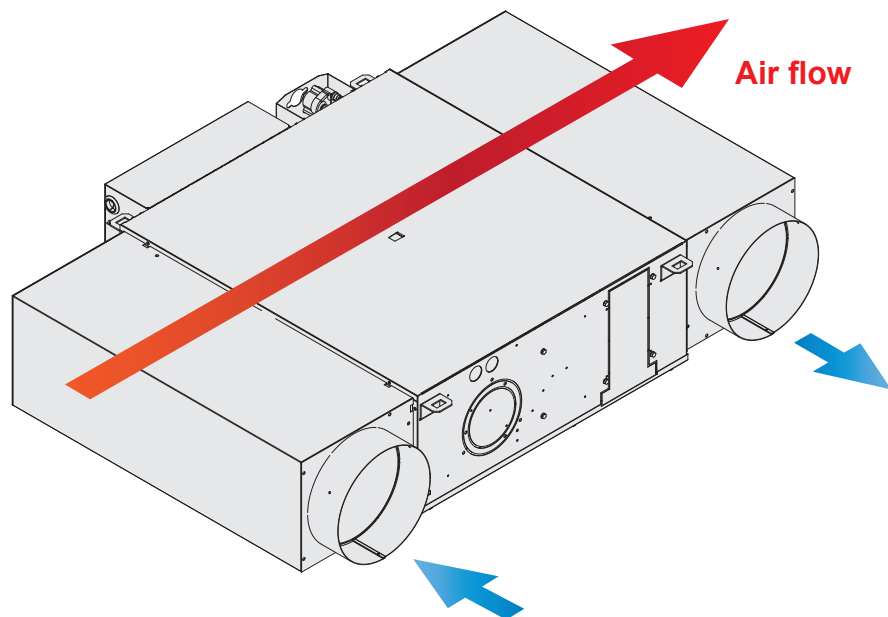

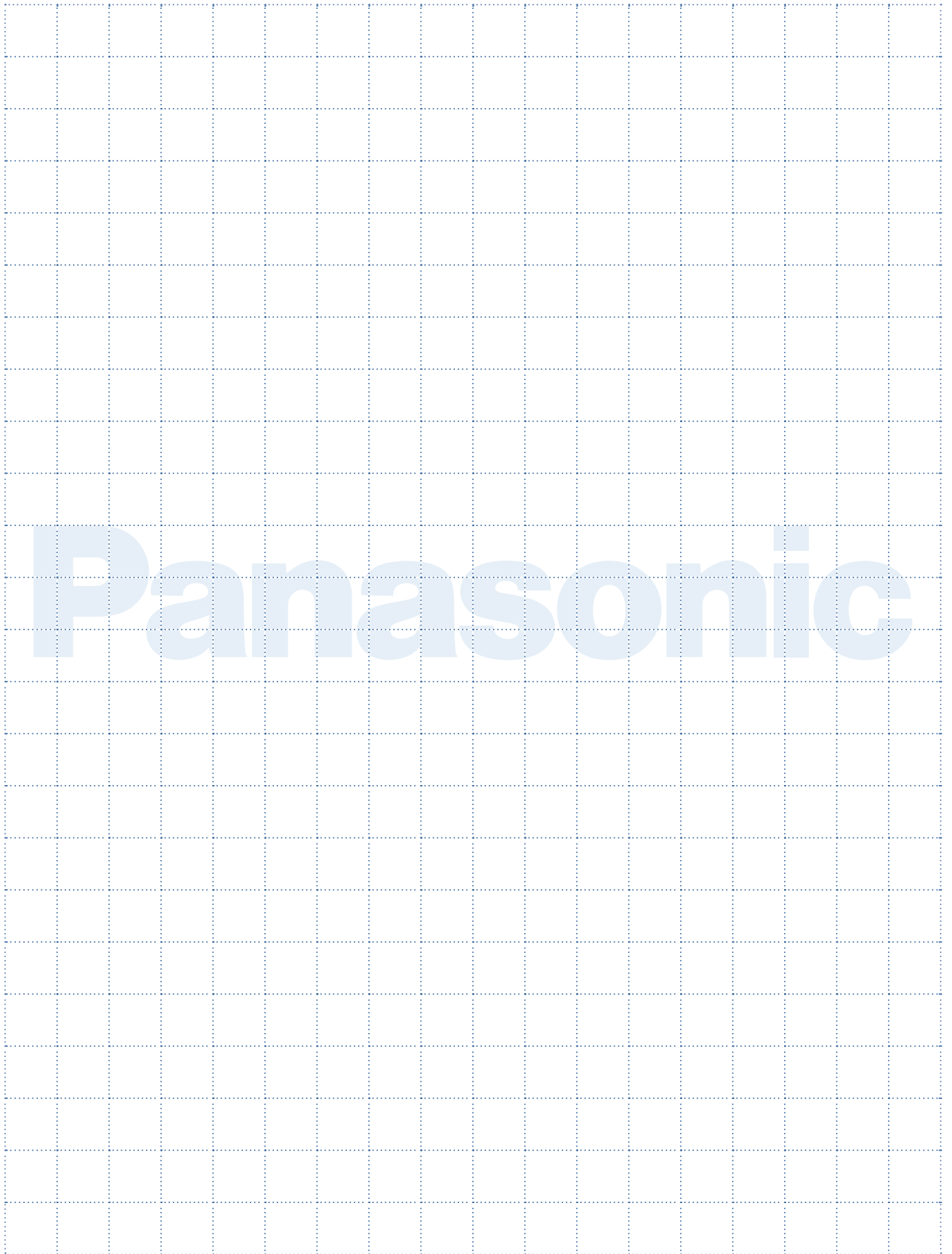

Panasonic Heating & Ventilation Air-Conditioning France SAS

Route de Verneuil
27570 Tillières-sur-Avre
FRANCE

☎ : +33 (0)2 32 60 61 00

📠 : +33 (0)2 32 32 55 13

www.aircon.panasonic.eu

TDM FAN COIL DUCT 01-P-1EN

June 2024

Supersedes : **None**