



Samsung Electronics

TDM+

Installation



General guide of pipe drawing (TDM+)

Samsung confidential

■ Pipe limitation – 4.4/6.6/9 kW 1 fan outdoor unit

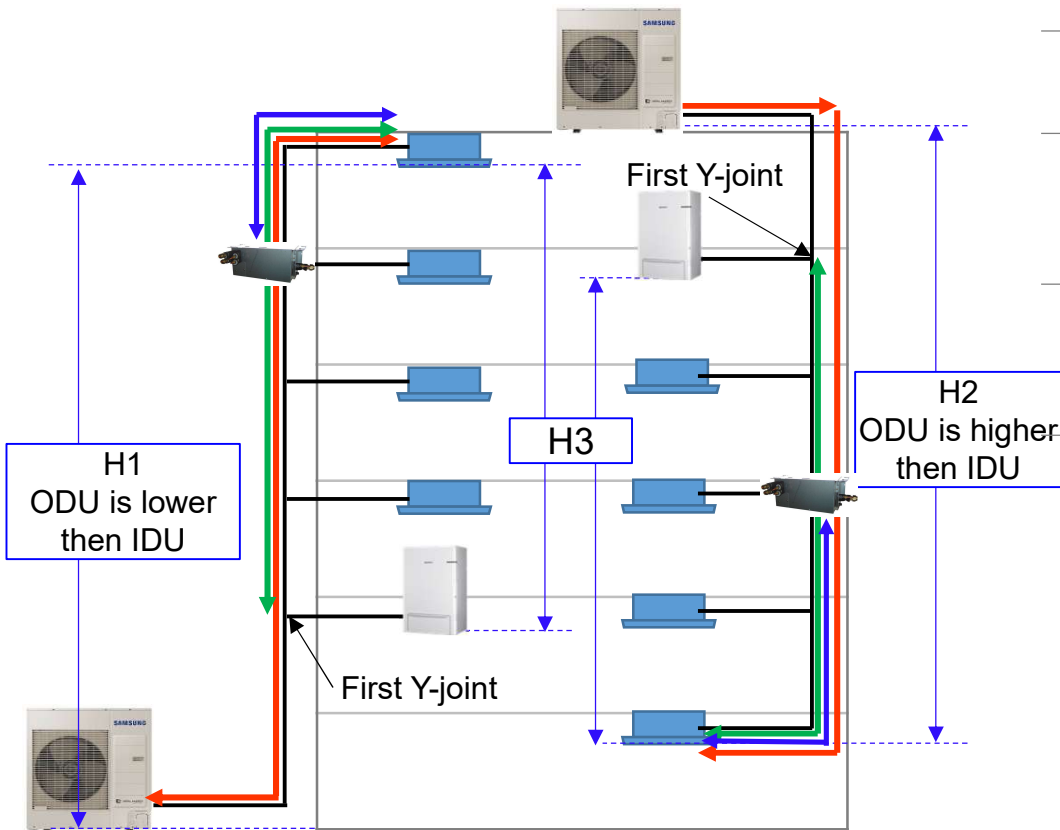

| Category | | Length | Remark |
|-----------------------------------|------------|----------------------|-------------|
| Total | | 5m ≤ length ≤ 75m | Liquid only |
| ODU to IDU* | | 30m → *50m(9kW only) | ↔ |
| First Y-joint to the farthest IDU | | 20m | ↔ |
| EEV kit to the farthest IDU | | 20m | ↔ |
| Level difference | H1 ODU-IDU | 15m | |
| | H2 ODU-IDU | 20m | |
| | H3 IDU-IDU | 7.5m | |

※ Check installation manuals to find more information

- ※ If ODU to IDU* distance is above 30m, below things are required.
- Liquid pipe : 3/8" → 1/4"
 - (Additional refrigerant should be calculated by liquid pipe size)
 - Gas pipe should have trap at least 200mm before vertical line.

Pipe Installation exception condition in TDM+ (9kW)

Samsung confidential

■ Pipe installation exception condition : ODU to IDU distance 30m → 50m

- Gas pipe(A2W+A2A) should have trap at least 200mm before vertical line.
- Need to change liquid pipe from 3/8" to 1/4"
- ※ This installation exception condition applies only to Spain climate conditions.

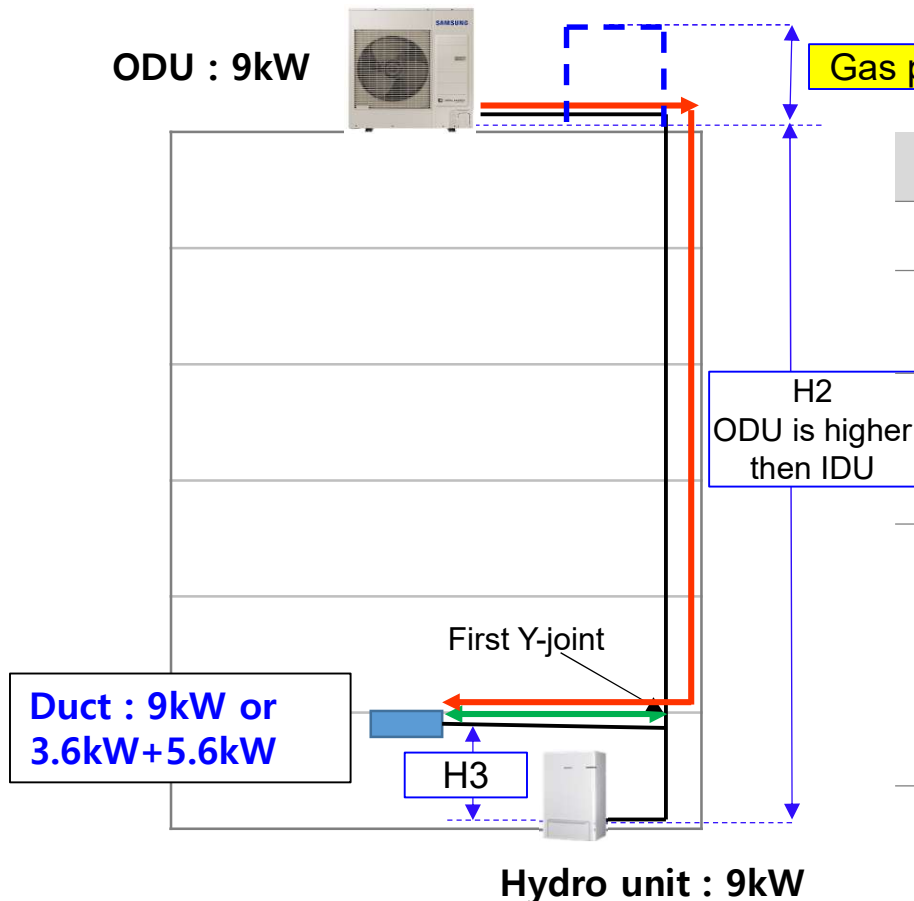

| Category | | Length | Remark |
|-----------------------------------|---------------|----------------------|-------------|
| Total | | 5m ≤ length ≤ 75m | Liquid only |
| ODU to IDU* | | 30m → *50m(9kW only) | ↔ |
| First Y-joint to the farthest IDU | | 20m | ↔ |
| Level difference | H2 ODU-IDU | 20m | |
| | H3 IDU-IDU | 7.5m | |

General guide of pipe drawing (TDM+)

Samsung confidential

■ Pipe limitation – 12/16 kW 2 fan outdoor unit

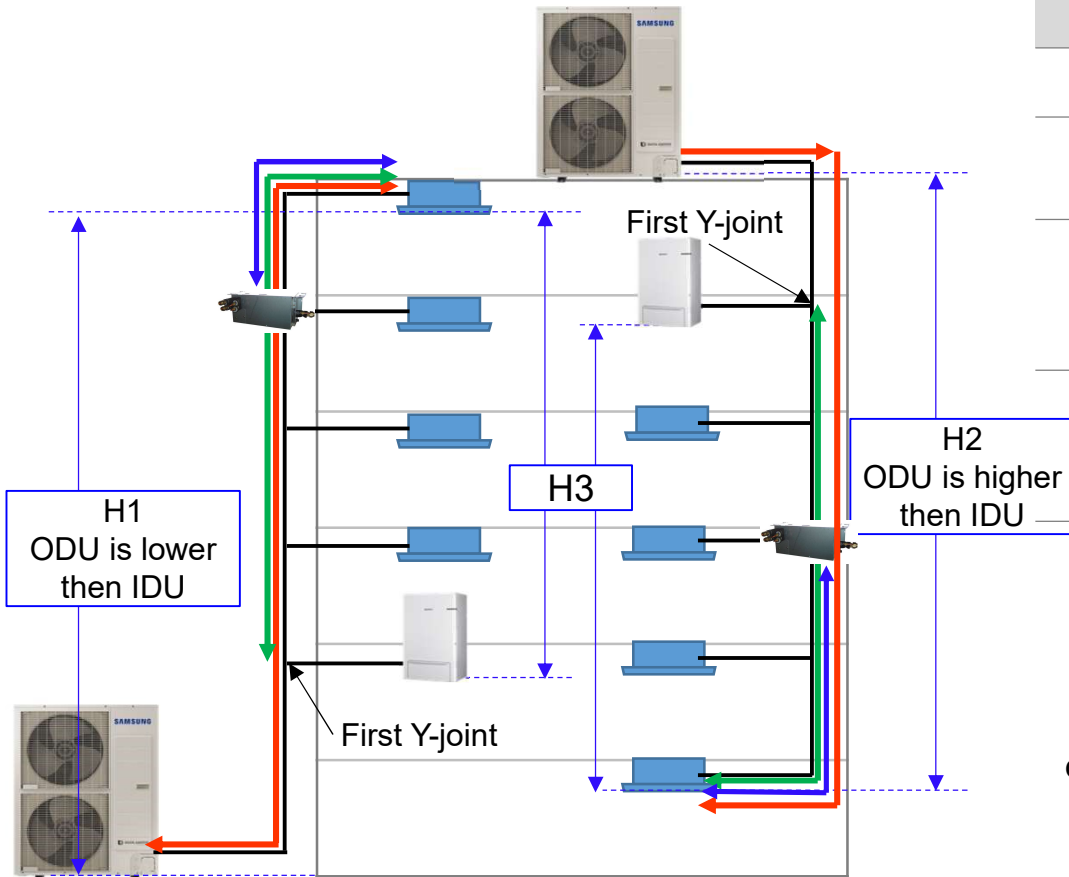

| Category | | Length | Remark |
|-----------------------------------|------------|---------------------|-------------|
| Total | | 10m ≤ length ≤ 200m | Liquid only |
| ODU to IDU | | 70m | ↔ |
| First Y-joint to the farthest IDU | | 40m | ↔ |
| EEV kit to the farthest IDU | | 20m | ↔ |
| Level difference | H1 ODU-IDU | 25m | |
| | H2 ODU-IDU | 30m | |
| | H3 IDU-IDU | 15m | |

※ Check installation manuals to find more information

Pipe Installation exception condition in TDM+ (9kW)

Samsung confidential

■ Pipe installation exception condition : ODU to IDU distance 30m → 50m

- Oil level test result : Complies with oil level specification in all test conditions

| Case) Max. refrigerant | Capacity | Amount of Refrigerant | Note |
|------------------------|----------|-----------------------|--------------|
| Outdoor unit | 9.0 kW | 2.40 kg | Basic charge |
| Duct - 1 | 3.6 kW | 0.26 kg | |
| Duct - 2 | 5.6 kW | 0.35 kg | |
| Total pipe length | 75m | 1.30 kg | 65m* x 20g/m |
| Total | | 4.31 kg | |

*Basic charge up to 10m

Ex) Oil level test result picture

